

Supercedes:
M5LCY-I-2010

Inverter-Y Single Split Series I

Models: M5LCY 10DR
M5LCY 15DR
M5LCY 20CR
M5LCY 25CR



Большая библиотека технической документации

<https://splitsystema48.ru/instrukcii-po-ekspluatácii-kondicionerov.html>

каталоги, инструкции, сервисные мануалы, схемы.

Table of Contents

Nomenclature	1
Indoor	1
Outdoor.....	1
Product Line-Up.....	3
Application Information	6
Operating Range	6
Refrigerant Circuit Diagram	6
Installation Guideline	7
Engineering & Physical Data	9
Safety Devices Data	14
Outline and Dimension	17
Wiring Diagram	21
Service and Maintenance	30
Troubleshooting	32
Exploded View and Part List	41

“McQuay” is a registered trademark of McQuay International. All rights reserved.

© 2011 McQuay International. All rights reserved throughout the world.

Bulletin illustrations cover the general appearance of McQuay International products at the time of publication.
We reserve the right to change design and construction specifications at any time without notice.

Nomenclature

Indoor

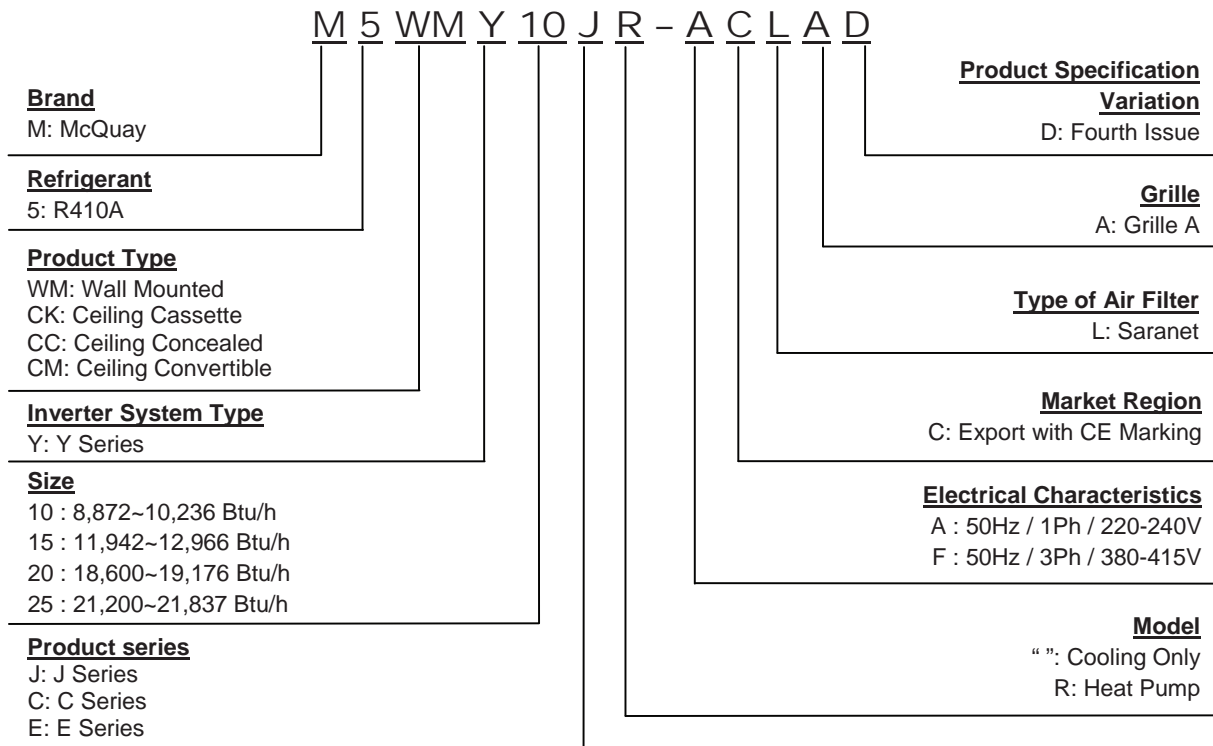

Outdoor

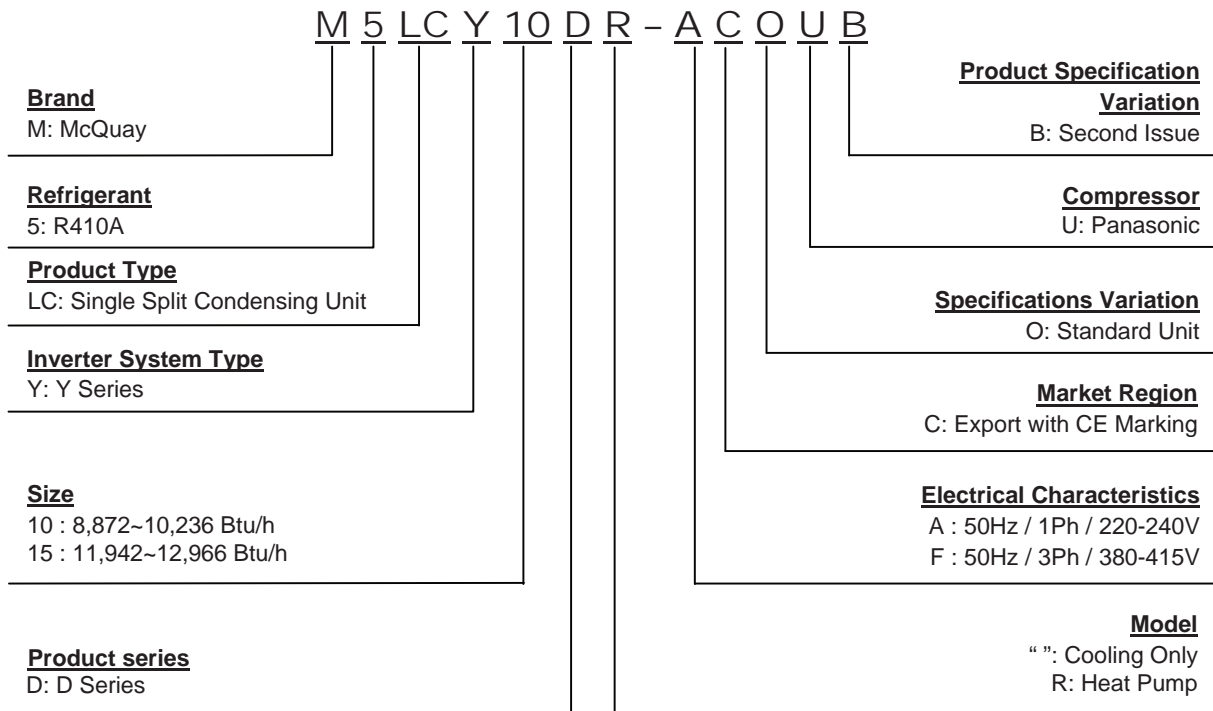

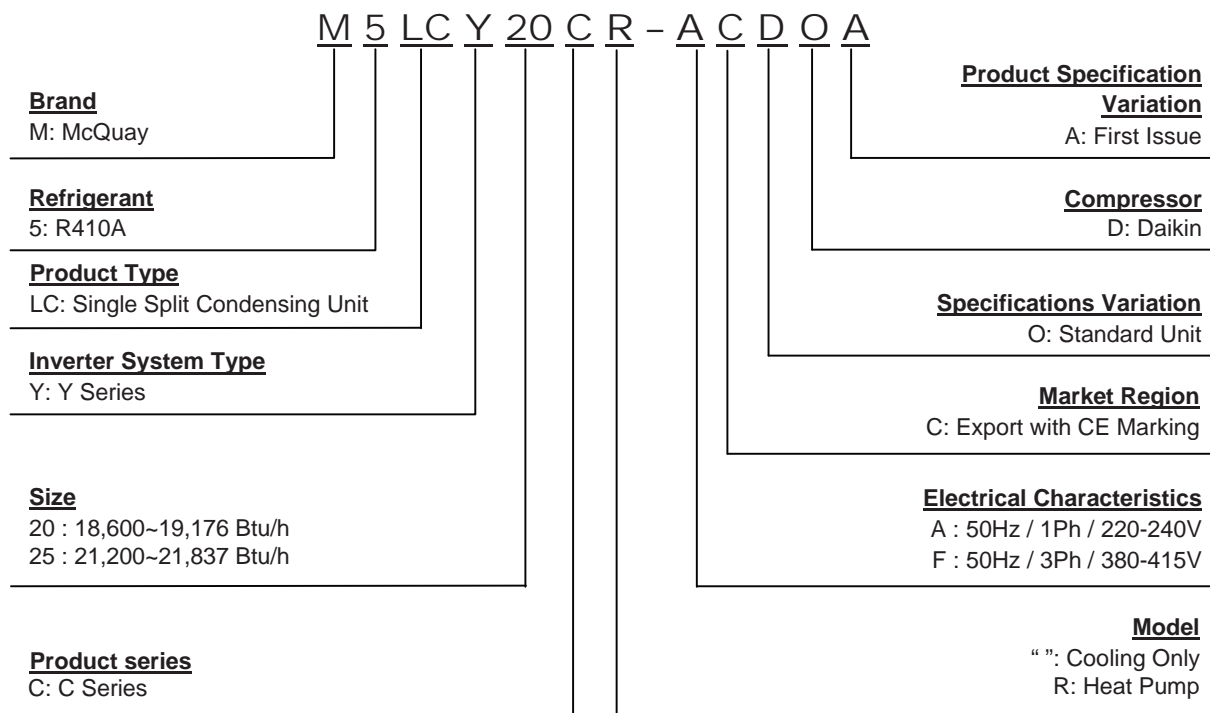

Product Line-Up

**Indoor Unit
M5WMY-J Series**

M5WMY		Nomenclature	Classification										
			Handset		PCB		Air Purification			Marking		Others	
			APGS01		W_2_03A		Saranet Filter	Negative Ionizer	Nano Technology Air Filtration	CE		Auto Restart	
HEATPUMP	10JR	ACLAD	X		X		X			X		X	
	15JR	ACLAD	X		X		X			X		X	
	20JR	ACLTC	X		X		X			X		X	
	25JR	ACLTC	X		X		X			X		X	

**Indoor Unit
M5CKY-C Series**

M5CKY		Nomenclature	Classification										
			Handset		PCB		Air Purification			Marking		Others	
			APGS01		C_2_01A_M		Saranet Filter	Negative Ionizer	Nano Technology Air Filtration	CE		Auto Restart	
HEATPUMP	10CR	ACOB			X					X		X	
	15CR	ACOB			X					X		X	
	20CR	ACOB			X					X		X	
	PLCKY-CR	NGS01	X				X			X			

**Indoor Unit
M5CKY-E Series**

M5CKY		Nomenclature	Classification										
			Handset		PCB		Air Purification			Marking		Others	
			APGS01		C_2_01A_M		Saranet Filter	Negative Ionizer	Nano Technology Air Filtration	CE		Auto Restart	
HEATPUMP	20ER	ACOB			X					X		X	
	25ER	ACOB			X					X		X	
	PLCKY-ER	NGS01	X				X			X			

**Indoor Unit
M5CCY-C Series**

M5CCY		Nomenclature	Classification										
			Handset		PCB		Air Purification			Marking		Others	
			Netware 3C		C_2_01A_M		Saranet Filter	Negative Ionizer	Nano Technology Air Filtration	CE		Auto Restart	
HEATPUMP	10CR	ACPA	X		X		X			X		X	
	15CR	ACPA	X		X		X			X		X	
	20CR	ACPA	X		X		X			X		X	
	25CR	ACPA	X		X		X			X		X	

**Indoor Unit
M5CMY-E Series**

M5CMY		Nomenclature	Classification										
			Handset		PCB		Air Purification			Marking		Others	
			APGS01		C_2_01A_M		Saranet Filter	Negative Ionizer	Nano Technology Air Filtration	CE		Auto Restart	
HEATPUMP	15ER	ACAA	X		X		X			X		X	
	20ER	ACAA	X		X		X			X		X	
	25ER	ACAA	X		X		X			X		X	

**Outdoor Unit
M5LCY**

M5LCY		Nomenclature	Classification														
			PCB		Refrigerant Control		FIN			Safety Devices			Compressor		Marking		Others
			OYL CONTROLLER		Cap Tube	EXV	Gold Coated	Blue Coated	Bare Fin	Contactar	HP	LP	DC Inverter Single Rotary	DC Inverter Swing Compressor	CE		
HEATPUMP	10DR	ACOUB	X			X		X				X		X			
	15DR	ACOUB	X			X		X				X		X			
	20CR	ACDOA	X			X		X				X		X			
	25CR	ACDOA	X			X		X				X		X			

Application Information

Operating Range

Ensure the operating temperature is in allowable range.

Heatpump

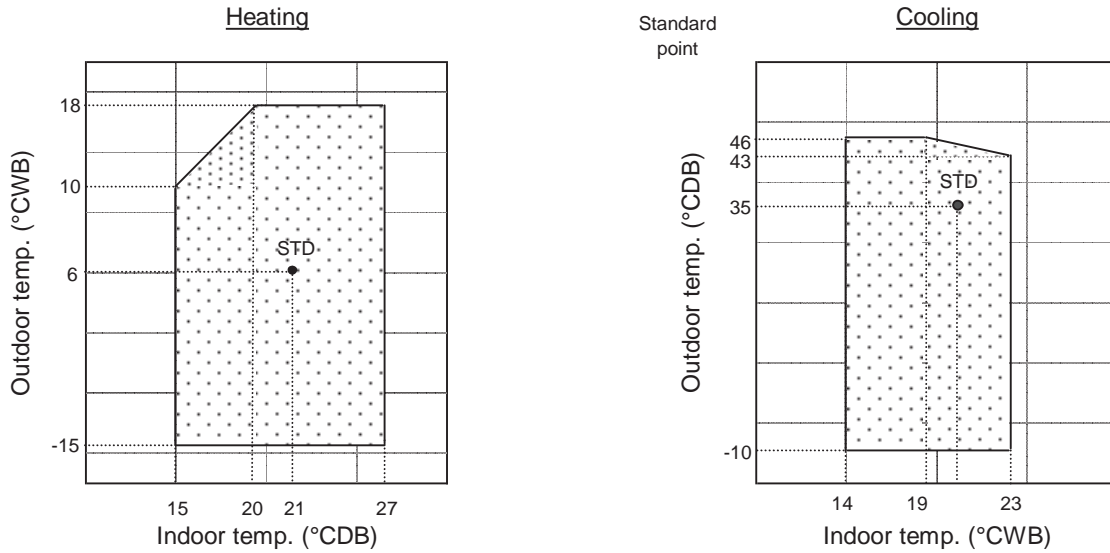

Caution :

The use of your air conditioner outside the range of working temperature and humidity can result in serious failure.

Refrigerant Circuit Diagram

Model: M5LCY 10DR - M5WMY 10JR / M5CKY 10CR / M5CCY 10CR
M5LCY 15DR - M5WMY 15JR / M5CKY 15CR / M5CCY 15CR / M5CMY 15ER
M5LCY 20CR - M5WMY 20JR / M5CKY 20C/ER / M5CCY 20CR / M5CMY 20ER
M5LCY 25CR - M5WMY 25JR / M5CKY 25ER / M5CCY 25CR / M5CMY 25ER

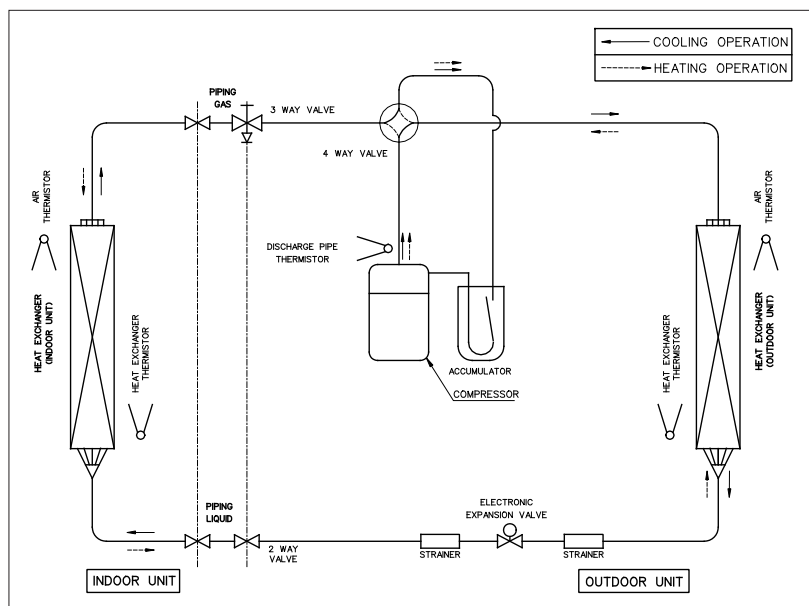

70034106462

Installation Guideline

Outdoor Unit Installation

- Where a wall or other obstacle is in the path of outdoor unit's intake or exhaust airflow, follow the installation guidelines below.

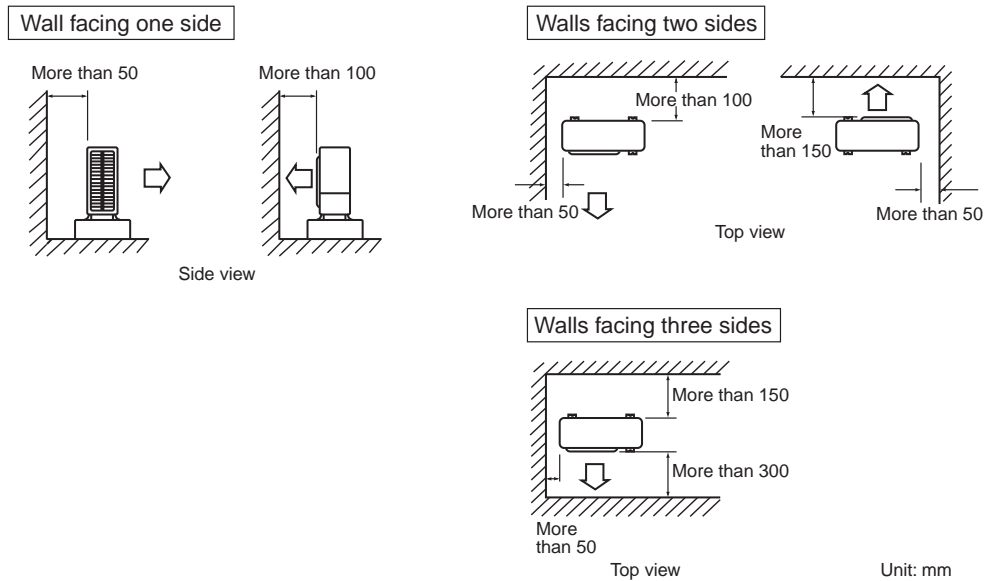

Electrical Wiring Connection

IMPORTANT : * The figures shown in the table are for information purpose only. They should be checked and selected to comply with the local/national codes of regulations. This is also subject to the type of installation and conductors used.

** The appropriate voltage range should be checked with label data on the unit.

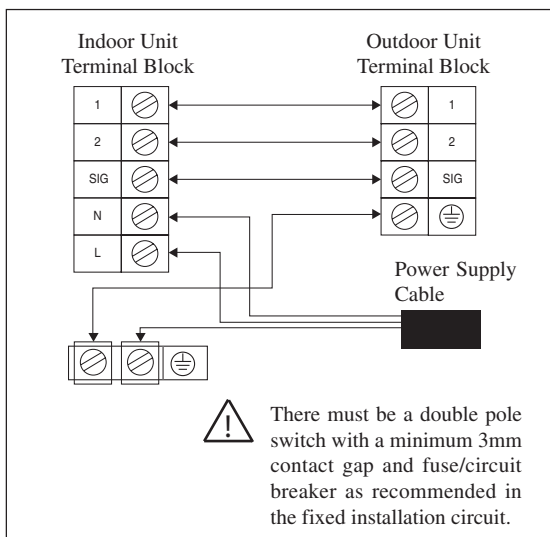

Model	10/15
Voltage range	220V-240V/ 1Ph/ 50Hz +⊕
Power supply cable size* mm2	1.5
Number of core	3
Power supply cable size* mm2	1.5
Number of core	4
Recommended time delay fuse A	15

* If the length of the cable is more than 2m, use cable with bigger size.

- All wires must be firmly connected.
- All wires must not touch the refrigerant piping, compressor or any moving parts of the fan motor.
- The connecting wires between the indoor unit and the outdoor unit must be clamped on the wire clamps.
- The power supply cord must be equivalent to H07RN-F (245IEC57) which is the minimum requirement.

Refrigerant Piping

Piping Length and Elevation

If the pipe is too long, both the capacity and reliability of the unit will drop. As the number of bends increases, resistance to the flow of refrigerant system increases, thus lowering cooling capacity. As a result, the compressor may become defective. Always choose the shortest path and follow the recommendations as tabulated below:

Outdoor	M5LCY10DR	M5LCY15DR	M5LCY20CR	M5LCY25CR
Indoor	M5WMY10JR	M5WMY15JR	M5WMY20JR	M5WMY25JR
Max. allowable length, m	15	15	30	30
Max. allowable elevation, m	10	10	10	10
Liquid pipe, mm	O.D. 6.4	O.D. 6.4	O.D. 6.4	O.D. 6.4
Gas pipe, mm	O.D. 9.5	O.D. 12.7	O.D. 12.7	O.D. 15.9
Additional charge of refrigerant, g/m (for piping length above 7.5m)	20	20	20	20

Outdoor	M5LCY10DR	M5LCY15DR	M5LCY20CR
Indoor	M5CKY10CR	M5CKY15CR	M5CKY20CR
Max. allowable length, m	15	15	30
Max. allowable elevation, m	10	10	10
Liquid pipe, mm	O.D. 6.4	O.D. 6.4	O.D. 6.4
Gas pipe, mm	O.D. 9.5	O.D. 12.7	O.D. 12.7
Additional charge of refrigerant, g/m (for piping length above 7.5m)	20	20	20

Outdoor	M5LCY20CR	M5LCY25CR
Indoor	M5CKY20ER	M5CKY25ER
Max. allowable length, m	30	30
Max. allowable elevation, m	10	10
Liquid pipe, mm	O.D. 6.4	O.D. 6.4
Gas pipe, mm	O.D. 12.7	O.D. 15.9
Additional charge of refrigerant, g/m (for piping length above 7.5m)	20	20

Outdoor	M5LCY10DR	M5LCY15DR	M5LCY20CR	M5LCY25CR
Indoor	M5CCY10CR	M5CCY15CR	M5CCY20CR	M5CCY25CR
Max. allowable length, m	15	15	30	30
Max. allowable elevation, m	10	10	10	10
Liquid pipe, mm	O.D. 6.4	O.D. 6.4	O.D. 6.4	O.D. 6.4
Gas pipe, mm	O.D. 9.5	O.D. 12.7	O.D. 12.7	O.D. 15.9
Additional charge of refrigerant, g/m (for piping length above 7.5m)	20	20	20	20

Outdoor	M5LCY15DR	M5LCY20CR	M5LCY25CR
Indoor	M5CMY15ER	M5CMY20ER	M5CMY25ER
Max. allowable length, m	15	30	30
Max. allowable elevation, m	10	10	10
Liquid pipe, mm	O.D. 6.4	O.D. 6.4	O.D. 6.4
Gas pipe, mm	O.D. 12.7	O.D. 12.7	O.D. 15.9
Additional charge of refrigerant, g/m (for piping length above 7.5m)	20	20	20

* Be sure to add the proper amount of additional refrigerant. Failure to do so may result in reduced performance.
Remark: The refrigerant pre-charged in the outdoor unit is for piping length up to 7.5m.

Engineering & Physical Data

MODEL: M5WMY-LR

MODEL	INDOOR UNIT			M5WMY10JR	M5WMY15JR	M5WMY20JR	M5WMY25JR				
	OUTDOOR UNIT			M5LCY10DR	M5LCY15DR	M5LCY20CR	M5LCY25CR				
NOMINAL COOLING CAPACITY				Btu/h	8872 (3754 - 11260)	11942 (4436 - 13307)	18600 (6415 - 21155)	21200 (6824 - 22178)			
				W	2600 (1100 - 3300)	3500 (1300 - 3900)	5450 (1880 - 6200)	6210 (2000 - 6500)			
NOMINAL HEATING CAPACITY				Btu/h	10236 (3412 - 13990)	12966 (3412 - 15696)	19176 (4504 - 22520)	21837 (5323 - 24226)			
				W	3000 (1000 - 4100)	3800 (1000 - 4600)	5620 (1320 - 6600)	6400 (1560 - 7100)			
NOMINAL TOTAL INPUT POWER (COOLING)				W	760	1050	1460	1880			
NOMINAL TOTAL INPUT POWER (HEATING)				W	828	1050	1500	1710			
NOMINAL RUNNING CURRENT (COOLING)				A	4.10	5.00	6.53	8.45			
NOMINAL RUNNING CURRENT (HEATING)				A	4.00	4.90	6.72	7.63			
EER				W/W	3.42	3.33	3.73	3.30			
COP				W/W	3.62	3.62	3.75	3.74			
REFRIGERANT CONTROL (EXPANSION DEVICE)				OUTDOOR EXV							
REFRIGERANT CHARGE				kg	0.75	1.10	1.45	1.50			
POWER SOURCE				V/Ph/Hz	220-240 /1/ 50						
REFRIGERANT TYPE				R410A							
INDOOR UNIT	CONTROL			AIR DISCHARGE OPERATION				AUTO LOUVER (UP & DOWN) & GRILLE (LEFT & RIGHT)			
								WIRELESS MICROCOMPUTER REMOTE CONTROL			
	AIR FLOW	TURBO			I/s / CFM	178 / 378	185 / 392	273 / 578	332 / 703		
		HIGH			I/s / CFM	153 / 324	160 / 337	250 / 529	309 / 654		
		MEDIUM			I/s / CFM	119 / 252	124 / 262	222 / 471	276 / 585		
		LOW			I/s / CFM	93 / 197	101 / 213	197 / 418	239 / 507		
		QUIET			I/s / CFM	86 / 182		177 / 374	206 / 437		
	SOUND PRESSURE LEVEL (SH/H/M/L/SL)				dB(A)	41 / 40 / 34 / 29 / 25	42 / 41 / 34 / 30 / 28	44 / 42 / 39 / 36 / 33	46 / 44 / 41 / 37 / 34		
	UNIT DIMENSION		HEIGHT X WIDTH X DEPTH		mm	288 X 800 X 206			310 X 1065 X 224		
	PACKING DIMENSION		HEIGHT X WIDTH X DEPTH		mm	351 X 894 X 280			386 X 1136 X 285		
	UNIT WEIGHT				kg	9			6.3		
	CONDENSATE DRAIN SIZE				mm	16			19.1		
	FAN		TYPE		CROSS FLOW FAN						
			DRIVE		DIRECT						
			TYPE		INDUCTION						
			INDEX OF PROTECTION (IP)		IP44		IP20				
			INSULATION GRADE		CLASS E						
	FAN MOTOR		RATED INPUT POWER		W	34	42	37	63		
			RATED RUNNING CURRENT		A	0.19	0.21	0.32	0.56		
			MOTOR OUTPUT		W	18		40			
		POLES		4		8					
COIL		TUBE		MATERIAL		SEAMLESS INNER GROOVE COPPER					
				DIAMETER		7.00					
		FIN		MATERIAL		ALUMINIUM (HYDROPHILIC FIN)					
				FACE AREA		0.18					
				ROW		2					
				FACE AREA		0.29					
				ROW		2					
AIR QUALITY		FILTER		TYPE		WASHABLE SARANET FILTER					
				QUANTITY		2					
CASING				COLOUR	WHITE						
OUTDOOR UNIT	AIR FLOW			I/s / CFM	521 / 1100	473 / 1000	869 / 1842				
	SOUND PRESSURE LEVEL				dB(A)	48	49	51			
	UNIT DIMENSION		HEIGHT X WIDTH X DEPTH		mm	550 X 765 X 285		753 X 855 X 328			
	PACKING DIMENSION		HEIGHT X WIDTH X DEPTH		mm	610 X 895 X 360		793 X 990 X 415			
	UNIT WEIGHT				kg	31	33	49			
	PIPE CONNECTION		TYPE		FLARE VALVE						
			SIZE		LIQUID		mm				
					GAS		mm				
					6.4	6.4	6.4	6.4			
					9.5	12.7	12.7	15.9			
	FAN		TYPE		PROPELLER						
			DRIVE		DIRECT						
			TYPE		INDUCTION						
			INDEX OF PROTECTION (IP)		IP24		IP34				
			INSULATION GRADE		CLASS E						
	FAN MOTOR		RATED INPUT POWER		W	66	67	120			
			RATED RUNNING CURRENT		A	0.31		0.52			
			MOTOR OUTPUT		W	26		66			
			POLES		6						
	COMPRESSOR		TYPE		ROTARY		ROTARY SWING				
		OIL TYPE		RB68A or FREOL ALPHA68M		ETHER					
		OIL AMOUNT		cm ³		320					
		RATED INPUT POWER (COOLING)		W	660	941	1296				
		RATED INPUT POWER (HEATING)		W	728	941	1334				
		RATED RUNNING CURRENT (COOLING)		A	3.6	4.48	5.66				
		RATED RUNNING CURRENT (HEATING)		A	3.5	4.38	5.84				
		LOCKED ROTOR AMP.		A							
COIL		TUBE		MATERIAL		SEAMLESS INNER GROOVE COPPER					
				DIAMETER		7.00					
		FIN		MATERIAL		ALUMINIUM (CORR.)					
				FACE AREA		0.42					
				ROW		1					
				FACE AREA		0.4					
				ROW		2					
CASING				COLOUR	LIGHT GREY						
DRAWING NUMBER				000452103D10	000452103D15	000452103E20	000452103E25				

ALL SPECIFICATIONS ARE SUBJECTED TO CHANGE BY THE MANUFACTURER WITHOUT PRIOR NOTICE.
 ALL UNITS ARE BEING TESTED AND COMPLY TO ISO 5151 (NON-DUCTED UNIT) OR ISO 13253 (DUCTED UNIT).

COOLING	HEATING
INDOOR: 27°C DB / 19°C WB	INDOOR: 20°C DB
OUTDOOR: 35°C DB / 24°C WB	OUTDOOR: 8°C DB / 6°C WB

MODEL: M5CKY-CR

MODEL		INDOOR UNIT		M5CKY10CR	M5CKY15CR	M5CKY20CR		
		OUTDOOR UNIT		M5LCY10DR	M5LCY15DR	M5LCY20CR		
NOMINAL COOLING CAPACITY		Btu/h		9792 (4026 - 11942)	12385 (5254 - 13306)	18118 (6346 - 20643)		
		W		2870 (1180 - 3500)	3630 (1540 - 3900)	5310 (1860 - 6050)		
NOMINAL HEATING CAPACITY		Btu/h		10884 (3753 - 13989)	13239 (3650 - 15865)	19039 (5050 - 19517)		
		W		3190 (1100 - 4100)	3880 (1070 - 4650)	5580 (1480 - 5720)		
NOMINAL TOTAL INPUT POWER (COOLING)		W		780	1006	1654		
NOMINAL TOTAL INPUT POWER (HEATING)		W		792	1024	1701		
NOMINAL RUNNING CURRENT (COOLING)		A		4.26	4.70	7.26		
NOMINAL RUNNING CURRENT (HEATING)		A		4.01	4.90	7.78		
EER		W/W		3.68	3.61	3.21		
COP		W/W		4.03	3.79	3.28		
REFRIGERANT CONTROL (EXPANSION DEVICE)				OUTDOOR EXV				
REFRIGERANT CHARGE		kg		0.75	1.10	1.45		
POWER SOURCE		V/Ph/Hz		220-240 /1/ 50				
REFRIGERANT TYPE				R410A				
INDOOR UNIT	CONTROL		AIR DISCHARGE OPERATION		4 WAY AUTOMATIC LOUVER (UP & DOWN)			
					WIRELESS OR WIRED MICROCOMPUTER REMOTE CONTROL			
	AIR FLOW	HIGH		l/s / CFM		193 / 410		212 / 450
		MEDIUM		l/s / CFM		184 / 390		203 / 430
		LOW		l/s / CFM		170 / 360		193 / 410
	SOUND PRESSURE LEVEL (H/M/L)		dBA		44 / 43 / 42		44 / 42 / 41	
	UNIT DIMENSION		HEIGHT X WIDTH X DEPTH		mm			250 X 570 X 570
	WITH PANEL		HEIGHT X WIDTH X DEPTH		mm			295 X 640 X 640
	PACKING DIMENSION		HEIGHT X WIDTH X DEPTH		mm			317 X 630 X 630
	PANEL		HEIGHT X WIDTH X DEPTH		mm			127 X 700 X 700
	UNIT WEIGHT (UNIT + PANEL)		kg		22 + 2		23 + 2	
	CONDENSATE DRAIN SIZE		mm		19.1			
	FAN		TYPE		TURBO			
			DRIVE		DIRECT			
	FAN MOTOR		TYPE		INDUCTION			
			INDEX OF PROTECTION (IP)		IP20			
			INSULATION GRADE		CLASS B			
			RATED INPUT POWER		W		152	
			RATED RUNNING CURRENT		A		0.67	
			MOTOR OUTPUT		W		50	
		POLES		6				
COIL		TUBE		MATERIAL		SEAMLESS INNER GROOVE COPPER		
		DIAMETER		mm		7.00		
		FIN		MATERIAL		ALUMINIUM (HYDROPHILIC FIN)		
				FACE AREA		m ²		
				ROW		2		
AIR QUALITY		FILTER		TYPE		WASHABLE SARANET FILTER		
				QUANTITY		1		
CASING		COLOUR		GREY				
OUTDOOR UNIT	AIR FLOW		l/s / CFM		521 / 1100		473 / 1000	
	SOUND PRESSURE LEVEL		dBA		48		49	
	UNIT DIMENSION		HEIGHT X WIDTH X DEPTH		mm			
	PACKING DIMENSION		HEIGHT X WIDTH X DEPTH		mm			
	UNIT WEIGHT		kg		31		33	
	PIPE CONNECTION		TYPE		FLARE VALVE			
			SIZE		LIQUID		mm	
					GAS		mm	
	FAN		TYPE		PROPELLER			
			DRIVE		DIRECT			
	FAN MOTOR		TYPE		INDUCTION			
			INDEX OF PROTECTION (IP)		IP24		IP34	
			INSULATION GRADE		CLASS E		CLASS F	
			RATED INPUT POWER		W		66	
			RATED RUNNING CURRENT		A		0.31	
			MOTOR OUTPUT		W		26	
			POLES		6			
	COMPRESSOR		TYPE		ROTARY		ROTARY SWING	
			OIL TYPE		RB68A or FREOL ALPHA68M		ETHER	
			OIL AMOUNT		cm ³		320	
		RATED INPUT POWER (COOLING)		W		660		
		RATED INPUT POWER (HEATING)		W		728		
		RATED RUNNING CURRENT (COOLING)		A		3.6		
		RATED RUNNING CURRENT (HEATING)		A		3.5		
		LOCKED ROTOR AMP.		A				
COIL		TUBE		MATERIAL		SEAMLESS INNER GROOVE COPPER		
		DIAMETER		mm		7.00		
		FIN		MATERIAL		ALUMINIUM (CORR.)		
				FACE AREA		m ²		
				ROW		1		
CASING		COLOUR		LIGHT GREY				
DRAWING NUMBER				000452103G10		000452103G15		
						000452103H20		

ALL SPECIFICATIONS ARE SUBJECTED TO CHANGE BY THE MANUFACTURER WITHOUT PRIOR NOTICE.
 ALL UNITS ARE BEING TESTED AND COMPLY TO ISO 5151 (NON-DUCTED UNIT) OR ISO 13253 (DUCTED UNIT).

COOLING	HEATING
INDOOR: 27°C DB / 19°C WB	INDOOR: 20°C DB
OUTDOOR: 35°C DB / 24°C WB	OUTDOOR: 8°C DB / 6°C WB

MODEL: M5CKY-ER

MODEL		INDOOR UNIT		M5CKY20ER		M5CKY25ER		
		OUTDOOR UNIT		M5LCY20CR		M5LCY25CR		
NOMINAL COOLING CAPACITY			Btu/h	18459 (5220 - 20608)	21564 (2081 - 21564)			
			W	5410 (1530 - 6040)	6320 (610 - 6320)			
NOMINAL HEATING CAPACITY			Btu/h	18868 (5323 - 20574)	22212 (5357 - 24873)			
			W	5530 (1560 - 6030)	6510 (1570 - 7290)			
NOMINAL TOTAL INPUT POWER (COOLING)			W	1587	1945			
NOMINAL TOTAL INPUT POWER (HEATING)			W	1495	1632			
NOMINAL RUNNING CURRENT (COOLING)			A	7.37	8.89			
NOMINAL RUNNING CURRENT (HEATING)			A	6.96	7.53			
EER			W/W	3.41	3.25			
COP			W/W	3.70	3.99			
REFRIGERANT CONTROL (EXPANSION DEVICE)			OUTDOOR EXV					
REFRIGERANT CHARGE			kg	1.45	1.50			
POWER SOURCE			V/Ph/Hz	220-240 /1/ 50				
REFRIGERANT TYPE			R410A					
INDOOR UNIT	CONTROL		AIR DISCHARGE OPERATION		4 WAY AUTOMATIC LOUVER (UP & DOWN) WIRELESS OR WIRED MICROCOMPUTER REMOTE CONTROL			
	AIR FLOW		HIGH	I/s / CFM	283 / 600	486 / 1030		
			MEDIUM	I/s / CFM	250 / 530	406 / 860		
			LOW	I/s / CFM	203 / 430	349 / 740		
	SOUND PRESSURE LEVEL (H/M/L)			dBA	34 / 31 / 28	44 / 41 / 38		
	UNIT DIMENSION		HEIGHT X WIDTH X DEPTH		mm			265 X 820 X 820
	WITH PANEL		HEIGHT X WIDTH X DEPTH		mm			340 X 990 X 990
	PACKING DIMENSION		HEIGHT X WIDTH X DEPTH		mm			335 X 900 X 900
	PANEL		HEIGHT X WIDTH X DEPTH		mm			410 X 1070 X 1070
	UNIT WEIGHT (UNIT + PANEL)			kg	29 + 6			
	CONDENSATE DRAIN SIZE			mm	19.1			
	FAN		TYPE		TURBO			
			DRIVE		DIRECT			
			TYPE		INDUCTION			
	FAN MOTOR		INDEX OF PROTECTION (IP)		IP20			
			INSULATION GRADE		CLASS B			
			RATED INPUT POWER	W	89	103		
			RATED RUNNING CURRENT	A	0.40	0.45		
			MOTOR OUTPUT	W	20	30		
			POLES		6			
COIL		TUBE	MATERIAL	SEAMLESS INNER GROOVE COPPER				
			DIAMETER	mm	7.00			
		FIN	MATERIAL	ALUMINIUM (HYDROPHILIC FIN)				
			FACE AREA	m ²	0.39			
			ROW	2				
AIR QUALITY		FILTER	TYPE	WASHABLE SARANET FILTER				
			QUANTITY	pc	1			
CASING			COLOUR	GREY				
OUTDOOR UNIT	AIR FLOW		I/s / CFM	869 / 1842				
	SOUND PRESSURE LEVEL			dBA	51			
	UNIT DIMENSION		HEIGHT X WIDTH X DEPTH		mm			753 X 922 X 392
	PACKING DIMENSION		HEIGHT X WIDTH X DEPTH		mm			793 X 990 X 415
	UNIT WEIGHT			kg	49			
	PIPE CONNECTION		TYPE		FLARE VALVE			
			SIZE	LIQUID	mm	6.4	6.4	
				GAS	mm	12.7	15.9	
	FAN		TYPE		PROPELLER			
			DRIVE		DIRECT			
			TYPE		INDUCTION			
	FAN MOTOR		INDEX OF PROTECTION (IP)		IP34			
			INSULATION GRADE		CLASS F			
			RATED INPUT POWER	W	120			
			RATED RUNNING CURRENT	A	0.52			
			MOTOR OUTPUT	W	66			
			POLES		6			
	COMPRESSOR		TYPE		ROTARY SWING			
			OIL TYPE		ETHER			
			OIL AMOUNT		cm ³			N/A
		RATED INPUT POWER (COOLING)	W	1296	1690			
		RATED INPUT POWER (HEATING)	W	1334	1518			
		RATED RUNNING CURRENT (COOLING)	A	5.66	7.25			
		RATED RUNNING CURRENT (HEATING)	A	5.84	6.52			
		LOCKED ROTOR AMP.		A				
COIL		TUBE	MATERIAL	SEAMLESS INNER GROOVE COPPER				
			DIAMETER	mm	7.00			
		FIN	MATERIAL	ALUMINIUM (CORR.)				
			FACE AREA	m ²	0.62			
			ROW	2				
CASING			COLOUR	LIGHT GREY				
DRAWING NUMBER				000452103N20	000452103N25			

ALL SPECIFICATIONS ARE SUBJECTED TO CHANGE BY THE MANUFACTURER WITHOUT PRIOR NOTICE.
 ALL UNITS ARE BEING TESTED AND COMPLY TO ISO 5151 (NON-DUCTED UNIT) OR ISO 13253 (DUCTED UNIT).

COOLING	HEATING
INDOOR: 27°C DB / 19°C WB	INDOOR: 20°C DB
OUTDOOR: 35°C DB / 24°C WB	OUTDOOR: 8°C DB / 6°C WB

MODEL: M5CCY-CR

MODEL		INDOOR UNIT		M5CCY10CR	M5CCY15CR	M5CCY20CR	M5CCY25CR		
		OUTDOOR UNIT		M5LCY10DR	M5LCY15DR	M5LCY20CR	M5LCY25CR		
NOMINAL COOLING CAPACITY		Btu/h		8769 (4504 - 11361)	12522 (5050 - 12829)	17742 (6892 - 20472)	20643 (6346 - 20643)		
		W		2570 (1320 - 3330)	3670 (1480 - 3760)	5200 (2020 - 6000)	6050 (1860 - 6050)		
NOMINAL HEATING CAPACITY		Btu/h		9451 (2389 - 12897)	12624 (3719 - 14671)	19687 (5391 - 22895)	21873 (5357 - 22758)		
		W		2770 (700 - 3780)	3700 (1090 - 4300)	5770 (1580 - 6710)	6400 (1570 - 6670)		
NOMINAL TOTAL INPUT POWER (COOLING)		W		791	1089	1604	1917		
NOMINAL TOTAL INPUT POWER (HEATING)		W		812	1066	1694	1775		
NOMINAL RUNNING CURRENT (COOLING)		A		4.43	4.91	7.34	8.90		
NOMINAL RUNNING CURRENT (HEATING)		A		4.29	4.80	7.74	8.11		
EER		W/W		3.25	3.37	3.24	3.21		
COP		W/W		3.41	3.47	3.41	3.66		
REFRIGERANT CONTROL (EXPANSION DEVICE)				OUTDOOR EXV					
REFRIGERANT CHARGE		kg		0.75	1.10	1.45	1.50		
POWER SOURCE		V/Ph/Hz		220-240 /1/ 50					
REFRIGERANT TYPE				R410A					
INDOOR UNIT	CONTROL		AIR DISCHARGE OPERATION		DUCTED				
					WIRED MICROCOMPUTER REMOTE CONTROL				
	AIR FLOW	HIGH	I/s / CFM		172 / 365	194 / 410	269 / 570	326 / 690	
		MEDIUM	I/s / CFM		160 / 340	175 / 370	255 / 540	302 / 640	
		LOW	I/s / CFM		137 / 290	118 / 250	213 / 450	245 / 520	
	EXTERNAL STATIC PRESSURE (H/M/L)		Pa		29 / 25 / 19		29 / 20 / 10		
	SOUND PRESSURE LEVEL (H/M/L)		dBA		35 / 32 / 26		37 / 34 / 29		
	UNIT DIMENSION		HEIGHT X WIDTH X DEPTH		mm		261 X 765 X 411		
	PACKING DIMENSION		HEIGHT X WIDTH X DEPTH		mm		376 X 1091 X 541		
	UNIT WEIGHT (UNIT + PANEL)		kg		9.5		11.3		
	CONDENSATE DRAIN SIZE		mm		19.1				
	FAN	TYPE				SIROCCO			
		DRIVE				DIRECT			
	FAN MOTOR	TYPE				INDUCTION			
		INDEX OF PROTECTION (IP)				N/A			
		INSULATION GRADE				CLASS B	CLASS E	CLASS B	
		RATED INPUT POWER		W		89	100	133	164
		RATED RUNNING CURRENT		A		0.39	0.42	0.61	0.74
		MOTOR OUTPUT		W		40	50	80	100
		POLES				4			
COIL	TUBE	MATERIAL		SEAMLESS INNER GROOVE COPPER					
		DIAMETER		mm		7.00			
	FIN	MATERIAL		ALUMINIUM (HYDROPHILIC FIN)					
		FACE AREA		m ²		0.13	0.16	0.19	
AIR QUALITY		FILTER		TYPE		WASHABLE SARANET FILTER			
				QUANTITY		1			
CASING		COLOUR		WITHOUT POWDER PAINT					
OUTDOOR UNIT	AIR FLOW		I/s / CFM		521 / 1100	473 / 1000	869 / 1842		
	SOUND PRESSURE LEVEL		dBA		48	49	51		
	UNIT DIMENSION		HEIGHT X WIDTH X DEPTH		mm		550 X 765 X 285		
	PACKING DIMENSION		HEIGHT X WIDTH X DEPTH		mm		610 X 895 X 360		
	UNIT WEIGHT		kg		31	33	49		
	PIPE CONNECTION	TYPE				FLARE VALVE			
		SIZE	LIQUID		mm		6.4	6.4	6.4
			GAS		mm		9.5	12.7	12.7
	FAN	TYPE				PROPELLER			
		DRIVE				DIRECT			
	FAN MOTOR	TYPE				INDUCTION			
		INDEX OF PROTECTION (IP)				IP24		IP34	
		INSULATION GRADE				CLASS E		CLASS F	
		RATED INPUT POWER		W		66	67	120	
		RATED RUNNING CURRENT		A		0.31		0.52	
		MOTOR OUTPUT		W		26	66		
		POLES				6			
	COMPRESSOR	TYPE				ROTARY		ROTARY SWING	
		OIL TYPE				RB68A or FREOL ALPHA68M		ETHER	
		OIL AMOUNT		cm ³		320		N/A	
RATED INPUT POWER (COOLING)		W		660	941	1296	1690		
RATED INPUT POWER (HEATING)		W		728	941	1334	1518		
RATED RUNNING CURRENT (COOLING)		A		3.6	4.48	5.66	7.25		
RATED RUNNING CURRENT (HEATING)		A		3.5	4.38	5.84	6.52		
LOCKED ROTOR AMP.		A		-					
COIL	TUBE	MATERIAL		SEAMLESS INNER GROOVE COPPER					
		DIAMETER		mm		7.00			
	FIN	MATERIAL		ALUMINIUM (CORR.)					
		FACE AREA		m ²		0.42	0.4	0.62	
		ROW		1		2			
CASING		COLOUR		LIGHT GREY					
DRAWING NUMBER				000452113J10	000452113J15	000452113K20	000452113K25		

ALL SPECIFICATIONS ARE SUBJECTED TO CHANGE BY THE MANUFACTURER WITHOUT PRIOR NOTICE.
 ALL UNITS ARE BEING TESTED AND COMPLY TO ISO 5151 (NON-DUCTED UNIT) OR ISO 13253 (DUCTED UNIT).

COOLING	HEATING
INDOOR: 27°C DB / 19°C WB	INDOOR: 20°C DB
OUTDOOR: 35°C DB / 24°C WB	OUTDOOR: 8°C DB / 6°C WB

MODEL: M5CMY-ER

MODEL	INDOOR UNIT			M5CMY15ER	M5CMY20ER	M5CMY25ER	
	OUTDOOR UNIT			M5LCY15DR	M5LCY20CR	M5LCY25CR	
NOMINAL COOLING CAPACITY	Btu/h			12249 (5936 - 14671)	18322 (5527 - 20199)	20608 (5323 - 21291)	
	W			3590 (1740 - 4300)	5370 (1620 - 5920)	6040 (1560 - 6240)	
NOMINAL HEATING CAPACITY	Btu/h			13170 (3650 - 16991)	19039 (5220 - 20199)	21086 (5596 - 21700)	
	W			3860 (1070 - 4980)	5580 (1530 - 5920)	6180 (164 - 6360)	
NOMINAL TOTAL INPUT POWER (COOLING)	W			928	1683	2007	
NOMINAL TOTAL INPUT POWER (HEATING)	W			972	1617	1873	
NOMINAL RUNNING CURRENT (COOLING)	A			4.55	7.75	9.23	
NOMINAL RUNNING CURRENT (HEATING)	A			4.68	7.45	8.52	
EER	W/W			3.87	3.19	3.01	
COP	W/W			3.97	3.45	3.30	
REFRIGERANT CONTROL (EXPANSION DEVICE)				OUTDOOR EXV			
REFRIGERANT CHARGE	kg			1.10	1.45	1.50	
POWER SOURCE	V/Ph/Hz			220-240 /1/ 50			
REFRIGERANT TYPE				R410A			
INDOOR UNIT	CONTROL	AIR DISCHARGE OPERATION			AUTOMATIC LOUVER (UP & DOWN)		
					WIRELESS OR WIRED MICROCOMPUTER REMOTE CONTROL		
	AIR FLOW	HIGH	l/s / CFM		240 / 508	245 / 520	274 / 580
		MEDIUM	l/s / CFM		182 / 386	217 / 460	250 / 530
		LOW	l/s / CFM		165 / 350	192 / 406	231 / 490
	SOUND PRESSURE LEVEL (H/M/L)	dBA		48 / 43 / 41	50 / 43 / 41	53 / 51 / 49	
	UNIT DIMENSION	HEIGHT X WIDTH X DEPTH		mm			218 X 1080 X 630
	PACKING DIMENSION	HEIGHT X WIDTH X DEPTH		mm			297 X 1197 X 740
	UNIT WEIGHT (UNIT + PANEL)	kg		25	27		
	CONDENSATE DRAIN SIZE	mm		19.1			
	FAN	TYPE			SIROCCO		
		DRIVE			DIRECT		
	FAN MOTOR	TYPE			INDUCTION		
		INDEX OF PROTECTION (IP)			N/A	IP20	
		INSULATION GRADE			CLASS B		
		RATED INPUT POWER	W		84	101	109
		RATED RUNNING CURRENT	A		0.37	0.46	0.49
		MOTOR OUTPUT	W		40	50	65
	POLES			4			
	COIL	TUBE	MATERIAL		SEAMLESS INNER GROOVE COPPER		
DIAMETER			mm			7.00	
FIN		MATERIAL		ALUMINIUM (HYDROPHILIC FIN)			
		FACE AREA		m ²			0.27
ROW		2		3			
AIR QUALITY	FILTER	TYPE			WASHABLE SARANET FILTER		
		QUANTITY			pc		2
CASING	COLOUR			LIGHT GREY			
OUTDOOR UNIT	AIR FLOW	l/s / CFM		473 / 1000	869 / 1842		
	SOUND PRESSURE LEVEL	dBA		49	51		
	UNIT DIMENSION	HEIGHT X WIDTH X DEPTH		mm			550 X 765 X 285
	PACKING DIMENSION	HEIGHT X WIDTH X DEPTH		mm			610 X 895 X 360
	UNIT WEIGHT	kg		33	49		
	PIPE CONNECTION	TYPE			FLARE VALVE		
		SIZE	LIQUID	mm	6.4	6.4	6.4
			GAS	mm	12.7	12.7	15.9
	FAN	TYPE			PROPELLER		
		DRIVE			DIRECT		
	FAN MOTOR	TYPE			INDUCTION		
		INDEX OF PROTECTION (IP)			IP24	IP34	
		INSULATION GRADE			CLASS E	CLASS F	
		RATED INPUT POWER	W		67	120	
		RATED RUNNING CURRENT	A		0.31	0.52	
		MOTOR OUTPUT	W		26	66	
	POLES			6			
	COMPRESSOR	TYPE			ROTARY	ROTARY SWING	
		OIL TYPE			RB68A or FREOL ALPHA68M	ETHER	
		OIL AMOUNT			cm ³	320	N/A
RATED INPUT POWER (COOLING)		W		941	1296	1690	
RATED INPUT POWER (HEATING)		W		941	1334	1518	
RATED RUNNING CURRENT (COOLING)		A		4.48	5.66	7.25	
RATED RUNNING CURRENT (HEATING)		A		4.38	5.84	6.52	
LOCKED ROTOR AMP.			A				-
COIL	TUBE	MATERIAL		SEAMLESS INNER GROOVE COPPER			
		DIAMETER		mm			7.00
	FIN	MATERIAL		ALUMINIUM (CORR.)			
		FACE AREA		m ²			0.4
ROW		2		0.62			
CASING	COLOUR			LIGHT GREY			
DRAWING NUMBER				000452103L15	000452103M20	000452103M25	

ALL SPECIFICATIONS ARE SUBJECTED TO CHANGE BY THE MANUFACTURER WITHOUT PRIOR NOTICE.
 ALL UNITS ARE BEING TESTED AND COMPLY TO ISO 5151 (NON-DUCTED UNIT) OR ISO 13253 (DUCTED UNIT).

COOLING	HEATING
INDOOR: 27°C DB / 19°C WB	INDOOR: 20°C DB
OUTDOOR: 35°C DB / 24°C WB	OUTDOOR: 8°C DB / 6°C WB

Safety Devices Data

MODEL	OUTDOOR UNIT			M5LCY 10DR	M5LCY 15DR
	INDOOR UNIT			M5WMY 10JR	M5WMY 15JR
SAFETY DEVICE	HIGH PRESSURE SWITCH	TYPE		N/A	N/A
		OPEN	kPa / psi	N/A	N/A
		CLOSE	kPa / psi	N/A	N/A
	LOW PRESSURE SWITCH	TYPE		N/A	N/A
		OPEN	kPa / psi	N/A	N/A
		CLOSE	kPa / psi	N/A	N/A
	PHASE SEQUENCER				N/A
DISCHARGE THERMOSTAT SETTING			°C / °F	N/A	N/A

MODEL	OUTDOOR UNIT			M5LCY 20CR	M5LCY 25CR
	INDOOR UNIT			M5WMY 20JR	M5WMY 25JR
SAFETY DEVICE	HIGH PRESSURE SWITCH	TYPE		N/A	N/A
		OPEN	kPa / psi	N/A	N/A
		CLOSE	kPa / psi	N/A	N/A
	LOW PRESSURE SWITCH	TYPE		N/A	N/A
		OPEN	kPa / psi	N/A	N/A
		CLOSE	kPa / psi	N/A	N/A
	PHASE SEQUENCER				N/A
DISCHARGE THERMOSTAT SETTING			°C / °F	N/A	N/A

MODEL	OUTDOOR UNIT			M5LCY 10DR	M5LCY 15DR
	INDOOR UNIT			M5CKY 10CR	M5CKY 15CR
SAFETY DEVICE	HIGH PRESSURE SWITCH	TYPE		N/A	N/A
		OPEN	kPa / psi	N/A	N/A
		CLOSE	kPa / psi	N/A	N/A
	LOW PRESSURE SWITCH	TYPE		N/A	N/A
		OPEN	kPa / psi	N/A	N/A
		CLOSE	kPa / psi	N/A	N/A
	PHASE SEQUENCER				N/A
DISCHARGE THERMOSTAT SETTING			°C / °F	N/A	N/A

MODEL	OUTDOOR UNIT			M5LCY 20CR
	INDOOR UNIT			M5CKY 20CR
SAFETY DEVICE	HIGH PRESSURE SWITCH	TYPE		N/A
		OPEN	kPa / psi	N/A
		CLOSE	kPa / psi	N/A
	LOW PRESSURE SWITCH	TYPE		N/A
		OPEN	kPa / psi	N/A
		CLOSE	kPa / psi	N/A
	PHASE SEQUENCER			
DISCHARGE THERMOSTAT SETTING			°C / °F	N/A

1) ALL SPECIFICATIONS ARE SUBJECTED TO CHANGE BY THE MANUFACTURER WITHOUT PRIOR NOTICE.

Safety Devices Data

MODEL	OUTDOOR UNIT			M5LCY 20CR	M5LCY 25CR
	INDOOR UNIT			M5CKY 20ER	M5CKY 25ER
SAFETY DEVICE	HIGH PRESSURE SWITCH	TYPE		N/A	N/A
		OPEN	kPa / psi	N/A	N/A
		CLOSE	kPa / psi	N/A	N/A
	LOW PRESSURE SWITCH	TYPE		N/A	N/A
		OPEN	kPa / psi	N/A	N/A
		CLOSE	kPa / psi	N/A	N/A
	PHASE SEQUENCER			N/A	N/A
DISCHARGE THERMOSTAT SETTING			°C / °F	N/A	N/A

MODEL	OUTDOOR UNIT			M5LCY 10DR	M5LCY 15DR
	INDOOR UNIT			M5CCY 10CR	M5CCY 15CR
SAFETY DEVICE	HIGH PRESSURE SWITCH	TYPE		N/A	N/A
		OPEN	kPa / psi	N/A	N/A
		CLOSE	kPa / psi	N/A	N/A
	LOW PRESSURE SWITCH	TYPE		N/A	N/A
		OPEN	kPa / psi	N/A	N/A
		CLOSE	kPa / psi	N/A	N/A
	PHASE SEQUENCER			N/A	N/A
DISCHARGE THERMOSTAT SETTING			°C / °F	N/A	N/A

MODEL	OUTDOOR UNIT			M5LCY 20CR	M5LCY 25CR
	INDOOR UNIT			M5CCY 20CR	M5CCY 25CR
SAFETY DEVICE	HIGH PRESSURE SWITCH	TYPE		N/A	N/A
		OPEN	kPa / psi	N/A	N/A
		CLOSE	kPa / psi	N/A	N/A
	LOW PRESSURE SWITCH	TYPE		N/A	N/A
		OPEN	kPa / psi	N/A	N/A
		CLOSE	kPa / psi	N/A	N/A
	PHASE SEQUENCER			N/A	N/A
DISCHARGE THERMOSTAT SETTING			°C / °F	N/A	N/A

MODEL	OUTDOOR UNIT			M5LCY 15DR	M5LCY 20CR
	INDOOR UNIT			M5CMY 15ER	M5CMY 20ER
SAFETY DEVICE	HIGH PRESSURE SWITCH	TYPE		N/A	N/A
		OPEN	kPa / psi	N/A	N/A
		CLOSE	kPa / psi	N/A	N/A
	LOW PRESSURE SWITCH	TYPE		N/A	N/A
		OPEN	kPa / psi	N/A	N/A
		CLOSE	kPa / psi	N/A	N/A
	PHASE SEQUENCER			N/A	N/A
DISCHARGE THERMOSTAT SETTING			°C / °F	N/A	N/A

1) ALL SPECIFICATIONS ARE SUBJECTED TO CHANGE BY THE MANUFACTURER WITHOUT PRIOR NOTICE.

Safety Devices Data

MODEL	OUTDOOR UNIT			M5LCY 25CR	
	INDOOR UNIT			M5CMY 25ER	
SAFETY DEVICE	HIGH PRESSURE SWITCH	TYPE		N/A	
		OPEN	kPa / psi	N/A	
		CLOSE	kPa / psi	N/A	
	LOW PRESSURE SWITCH	TYPE		N/A	
		OPEN	kPa / psi	N/A	
		CLOSE	kPa / psi	N/A	
	PHASE SEQUENCER				N/A
	DISCHARGE THERMOSTAT SETTING		°C / °F	N/A	

1) ALL SPECIFICATIONS ARE SUBJECTED TO CHANGE BY THE MANUFACTURER WITHOUT PRIOR NOTICE.

Outline and Dimension

Outdoor Unit
Model: M5LCY 10/15DR

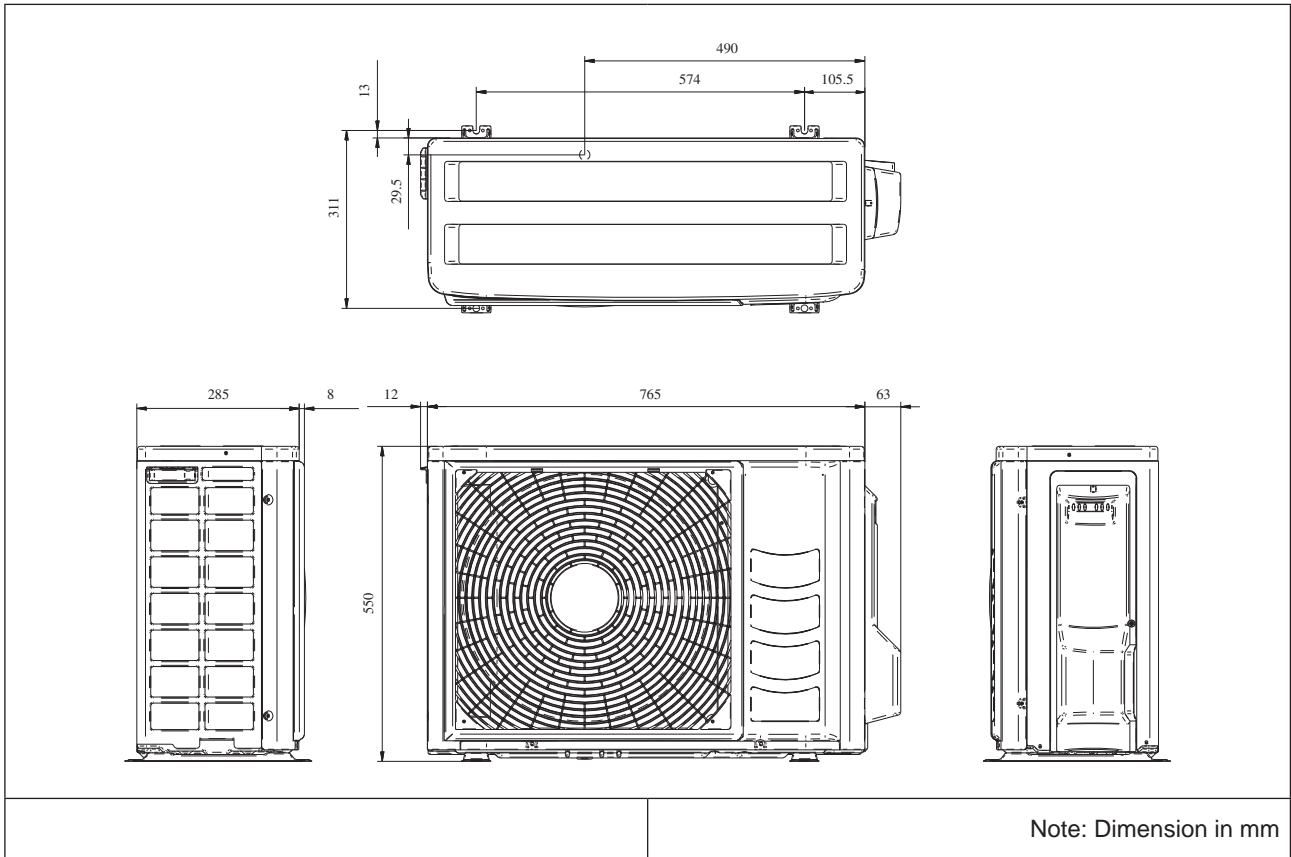

Outdoor Unit
Model: M5LCY 20/25CR

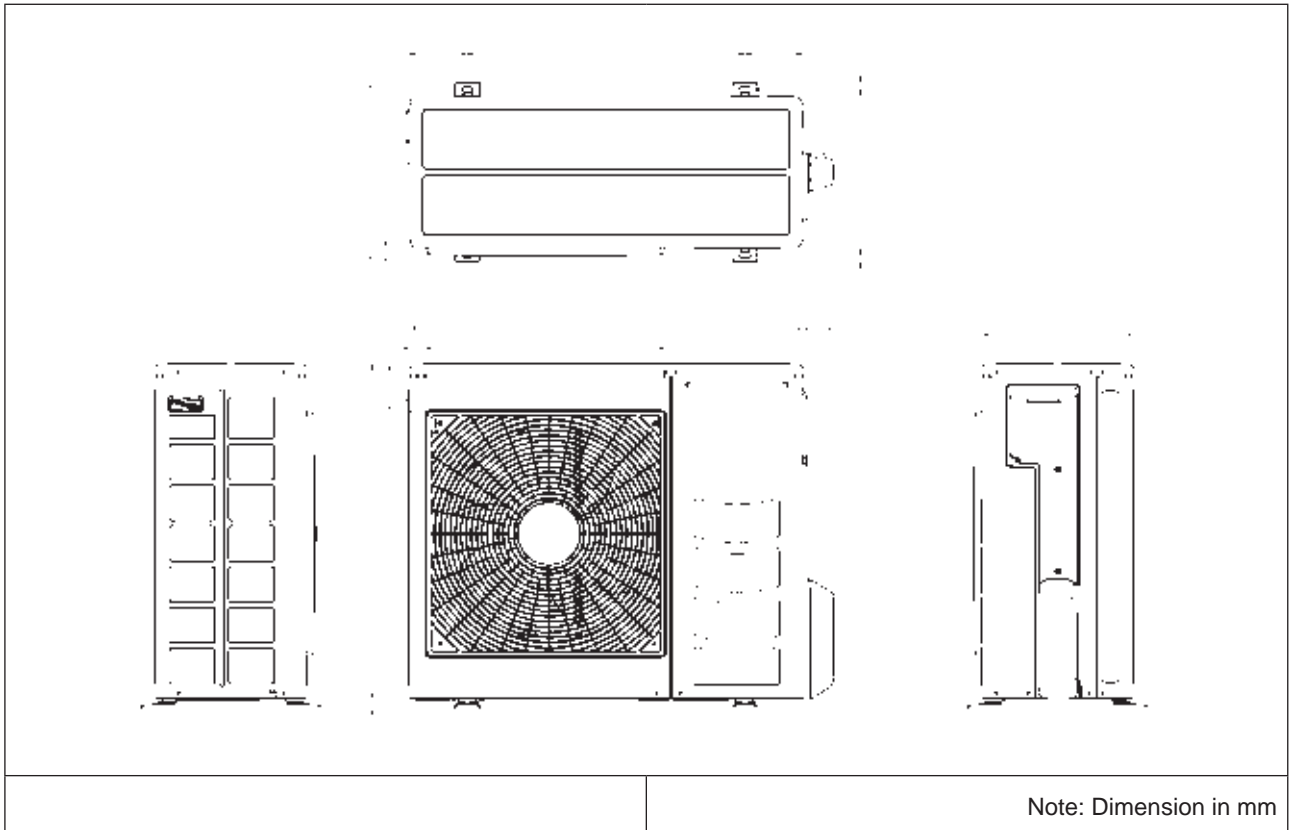

Indoor Unit
Model: M5WMY 10/15JR

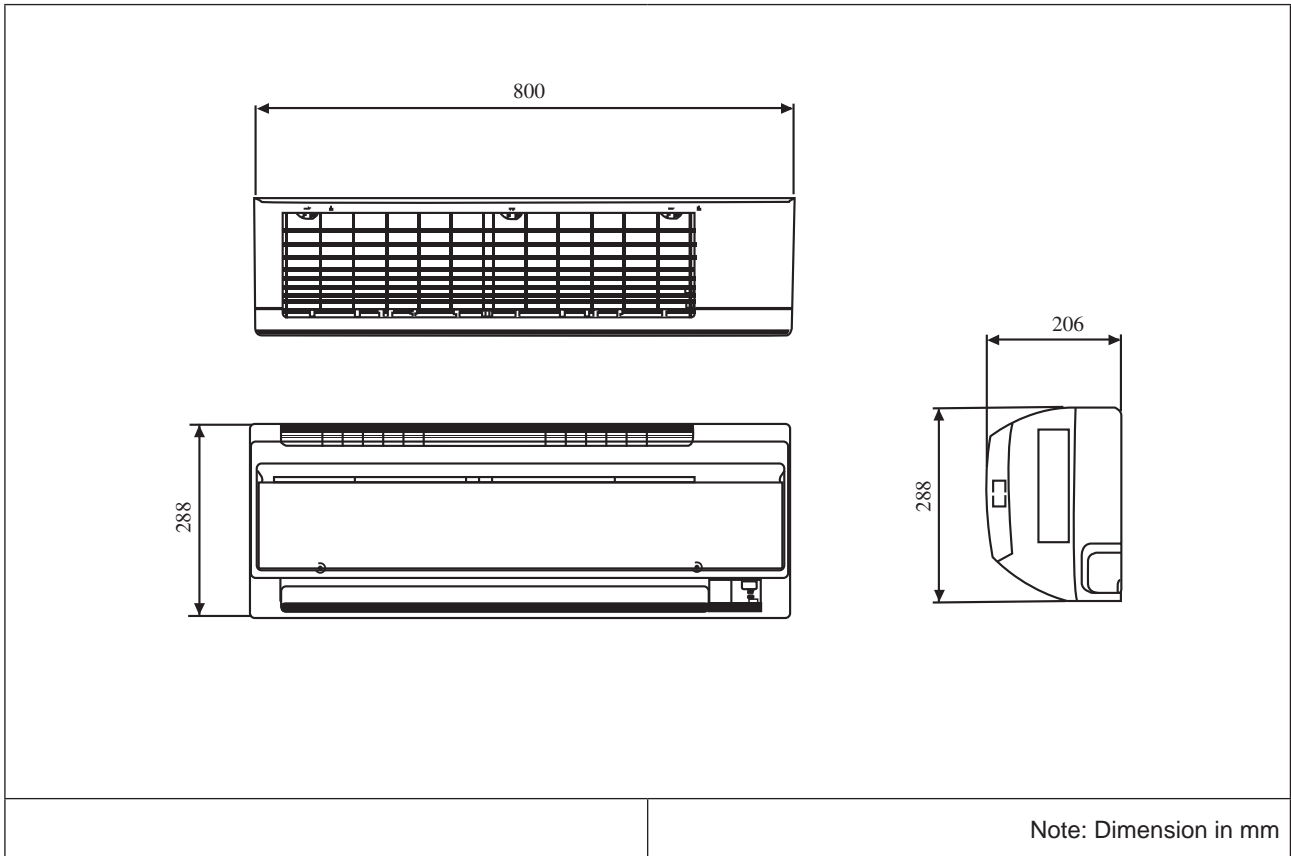

Indoor Unit
Model: M5WMY 20/25JR

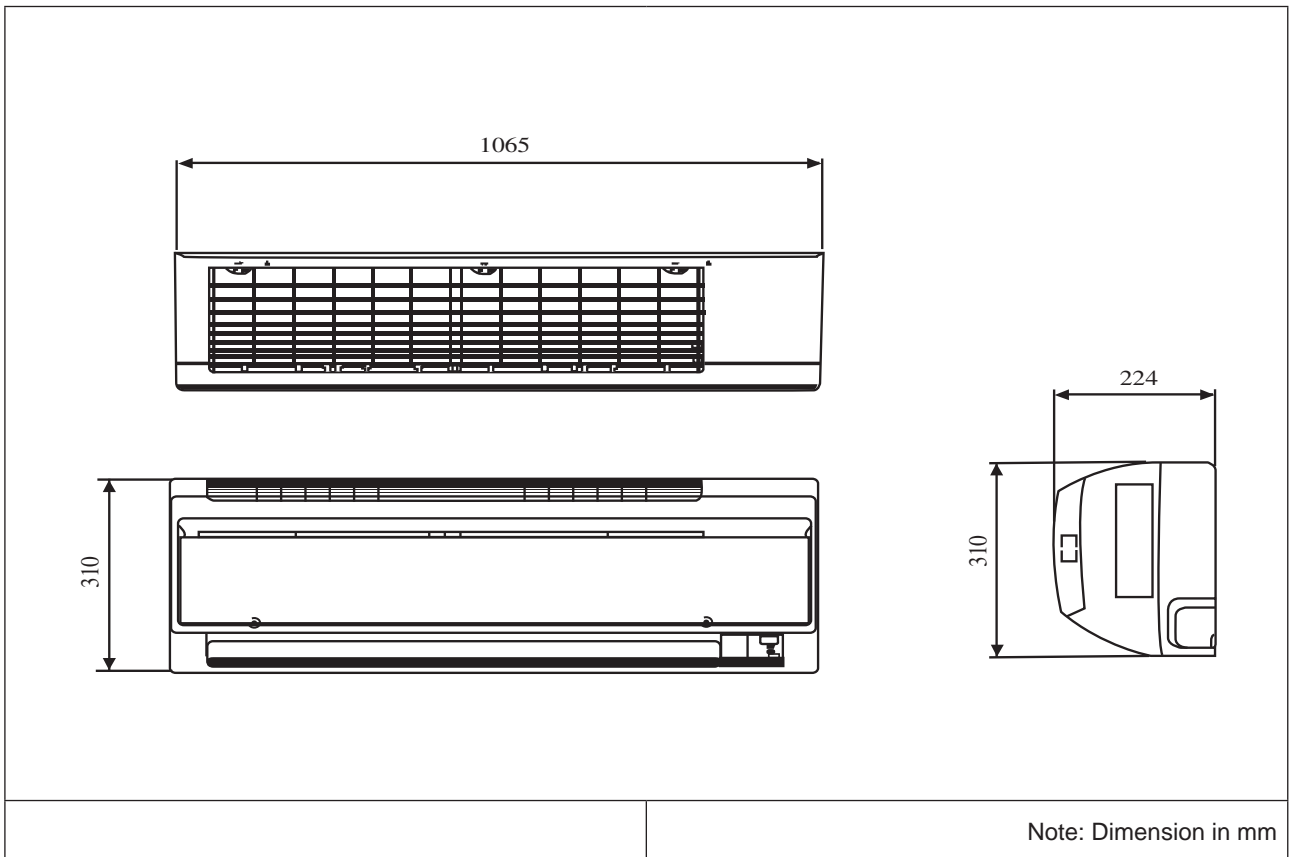

Indoor Unit
Model: M5CKY 10/15/20CR

MODEL	A	B	C	D	E	F	G	H	I	J	K
M5CKY 10/15/20CR	570	570	295	275	20	640	640	408	408	364	364

Note: Dimension in mm

Indoor Unit
Model: M5CKY 20/25ER

MODEL	A	B	C	D	E	F	G	H	I	J	K
M5CKY 20/25ER	820	820	350	290	60	990	990	627	627	607	607

Note: Dimension in mm

Indoor Unit
Model: M5CCY 10/15/20/25CR

MODEL	A	B	C	D	E	F	G	H	I	J	K	L	M	N	O
M5CCY 10/15CR	31	881	842	802	10	905	72	261	411	351	225	211	232	212.8	114
M5CCY 20CR	31	1041	1002	962	10	1065	72	261	411	351	225	211	232	212.8	114
M5CCY 25CR	31	1176	1137	1097	10	1200	72	261	411	351	225	211	232	212.8	114

Note: Dimension in mm

Indoor Unit
Model: M5CMY 15/20/25ER

Note: Dimension in mm

Wiring Diagram

Heat Pump

Outdoor Unit
Model: M5LCY 10/15DR

Indoor Unit
Model: M5WMY 10/15JR

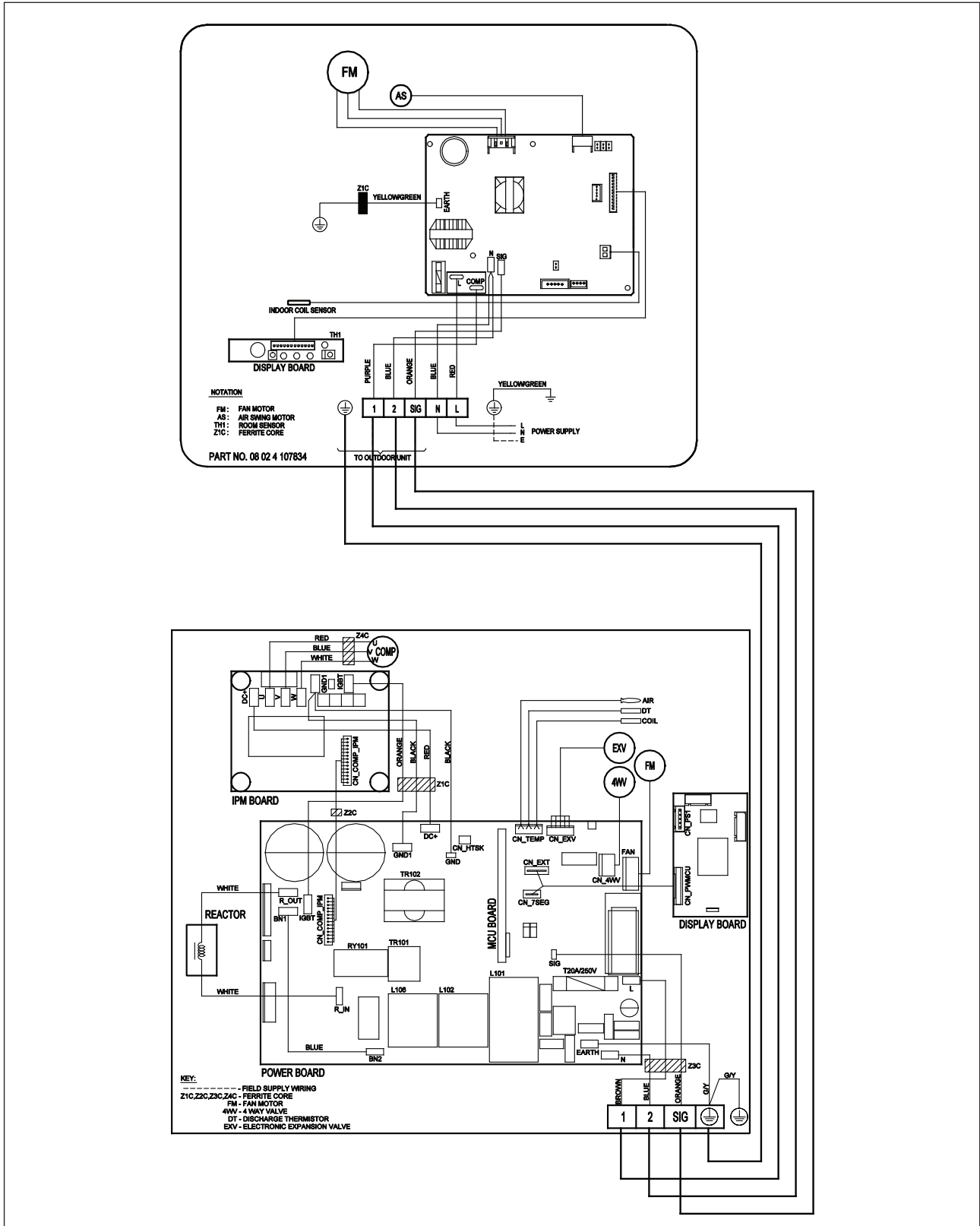

70034106463

Outdoor Unit
Model: M5LCY 20/25CR

Indoor Unit
Model: M5WMY 20/25JR

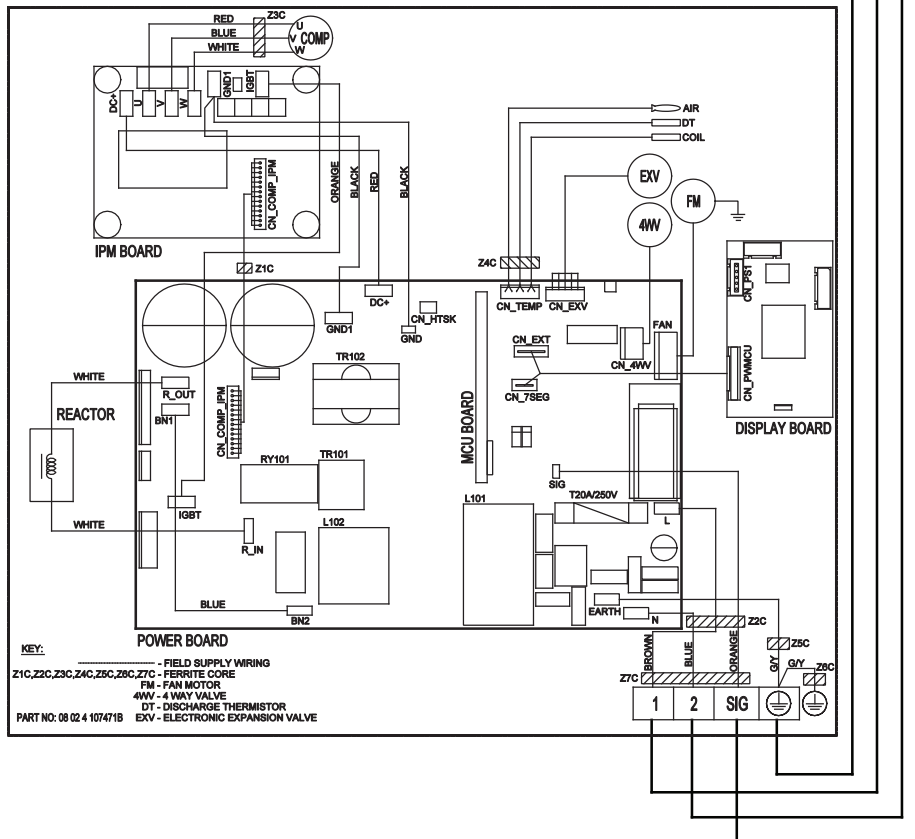
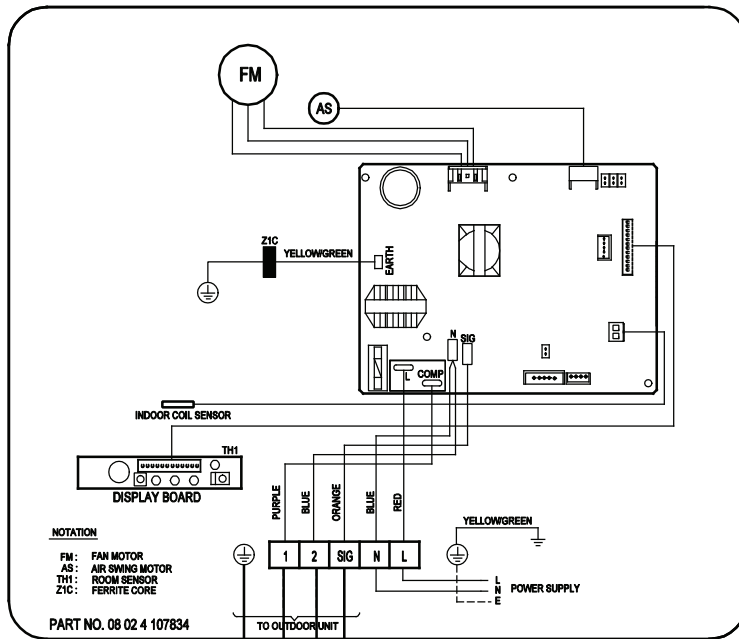

Heat Pump

Outdoor Unit
Model: M5LCY 10/15DR

Indoor Unit
Model: M5CKY 10/15CR

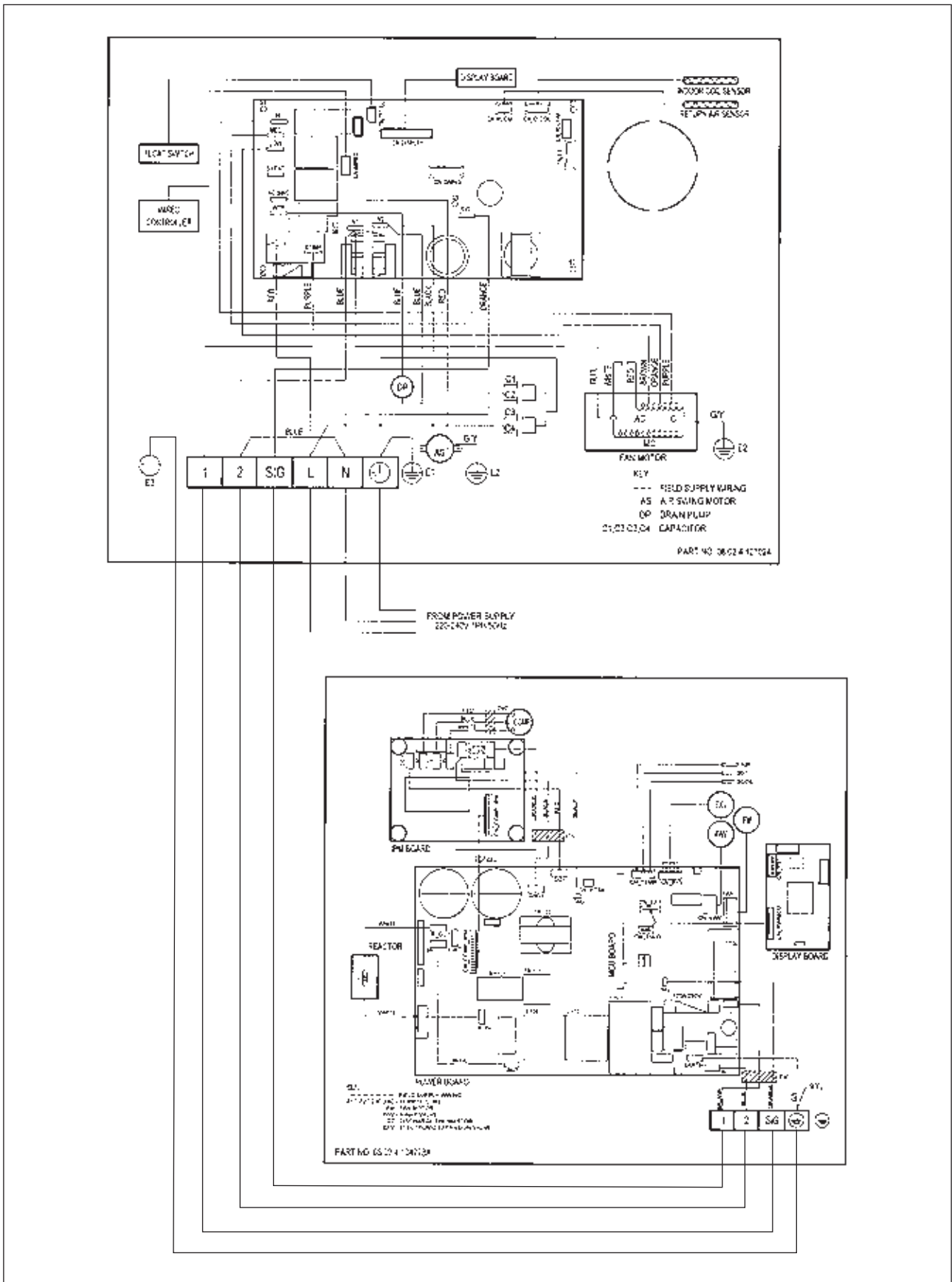

70034108590

Heat Pump

Outdoor Unit
Model: M5LCY 20CR

Indoor Unit
Model: M5CKY 20CR

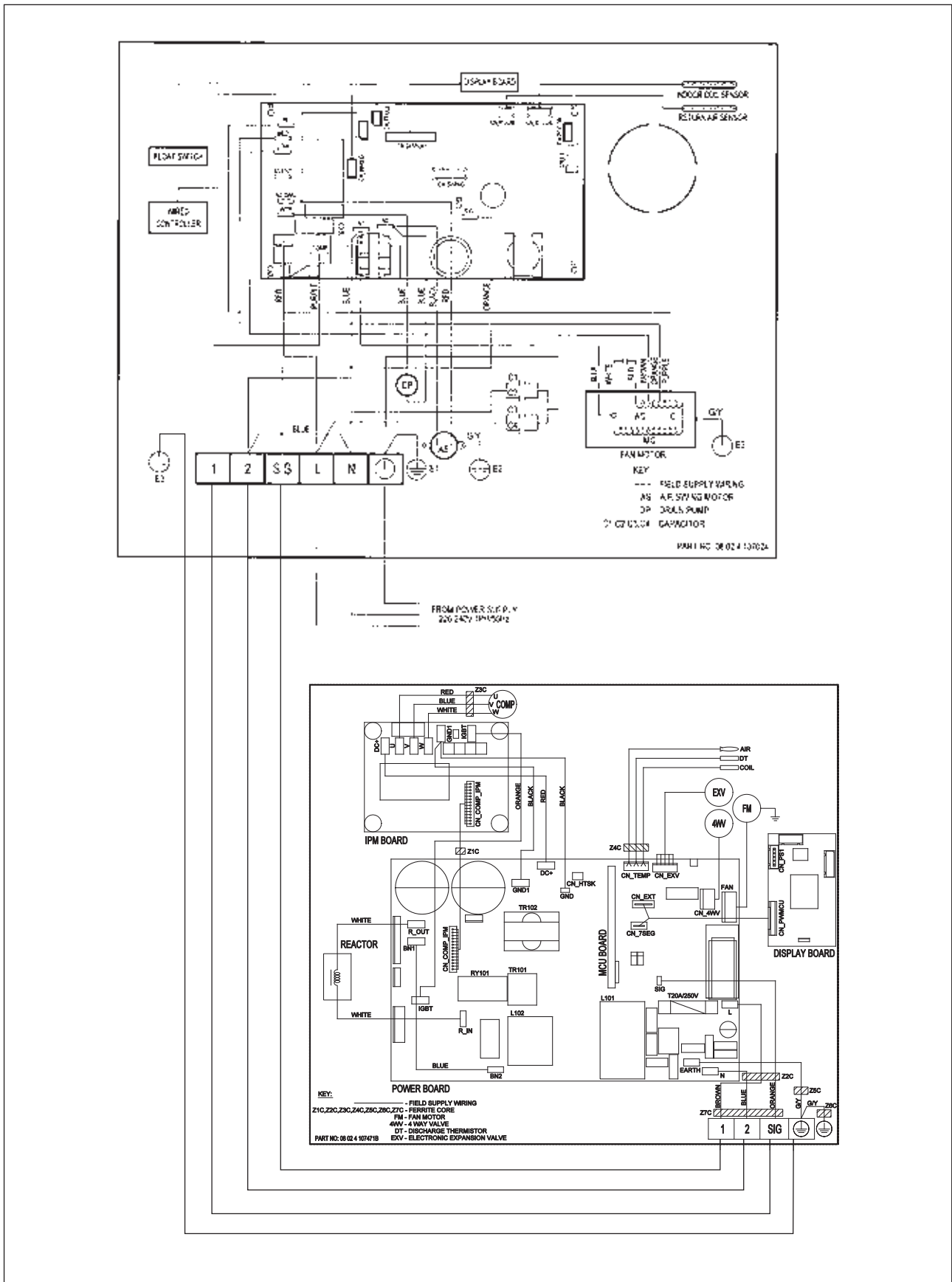

Heat Pump

Outdoor Unit
Model: M5LCY 20/25CR

Indoor Unit
Model: M5CKY 20/25ER

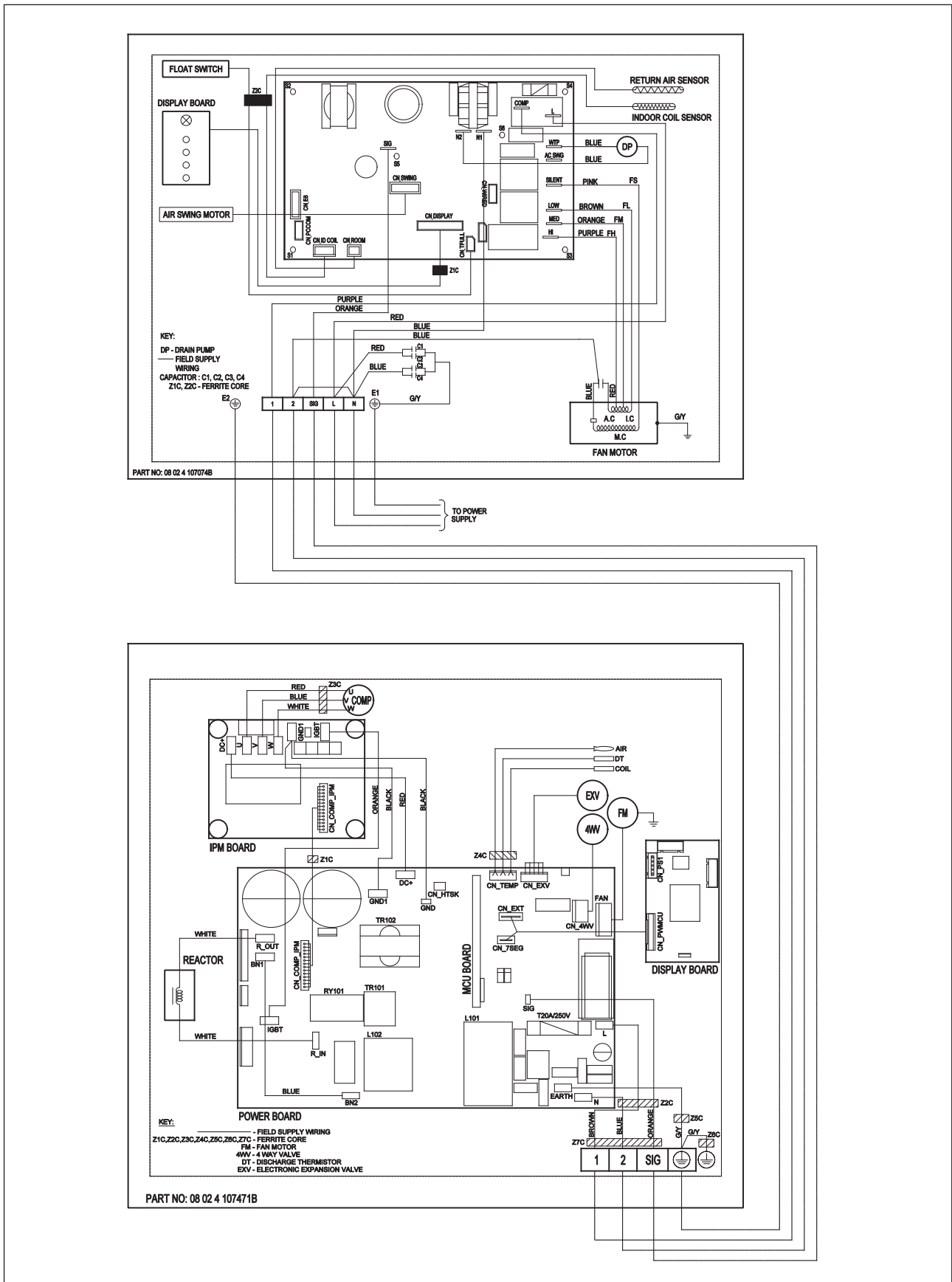

70034110364

Heat Pump

Outdoor Unit
Model: M5LCY 10/15DR

Indoor Unit
Model: M5CCY 10/15CR

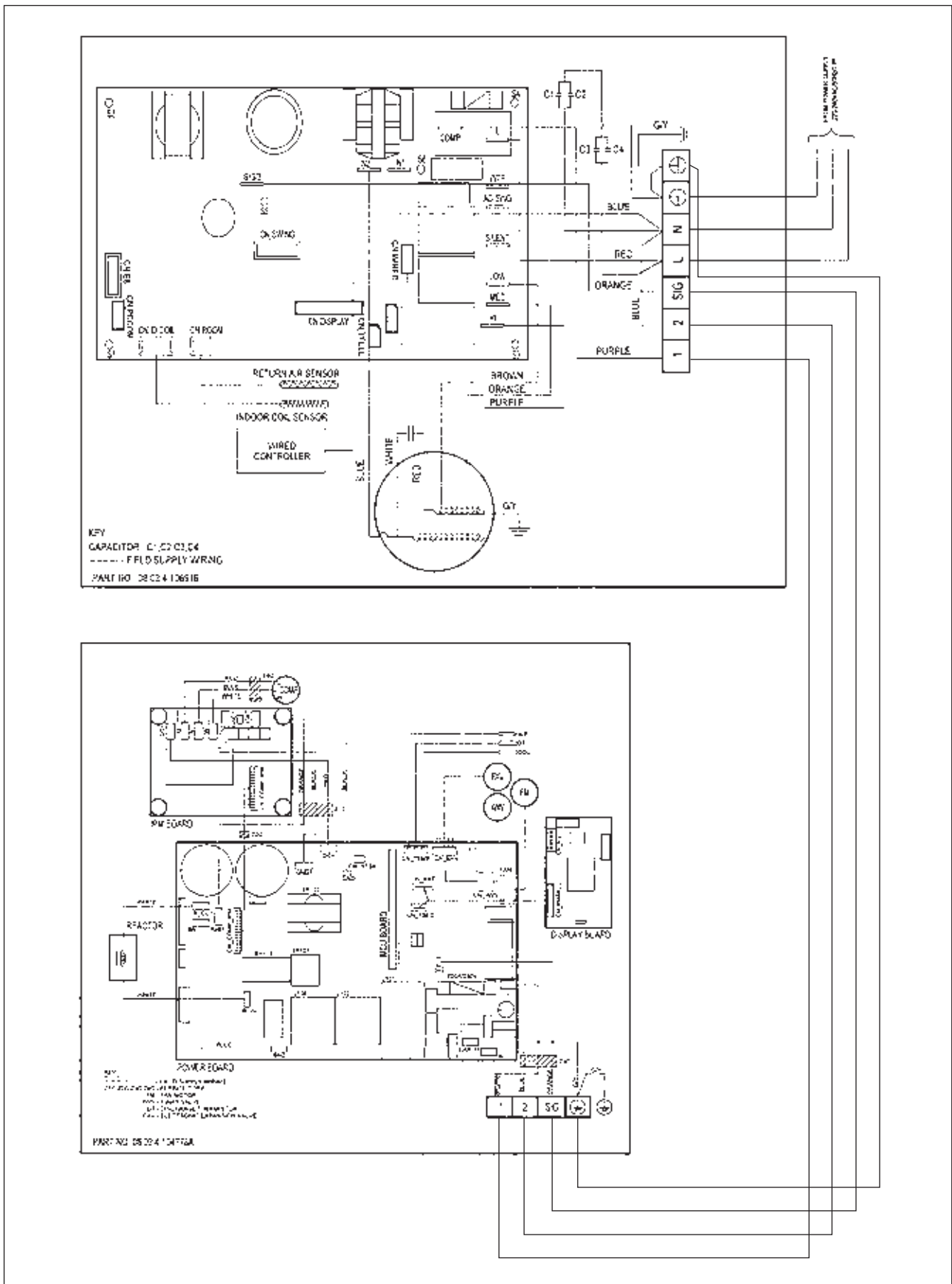

70034108589

Heat Pump

Outdoor Unit
Model: M5LCY 20/25CR

Indoor Unit
Model: M5CCY 20/25CR

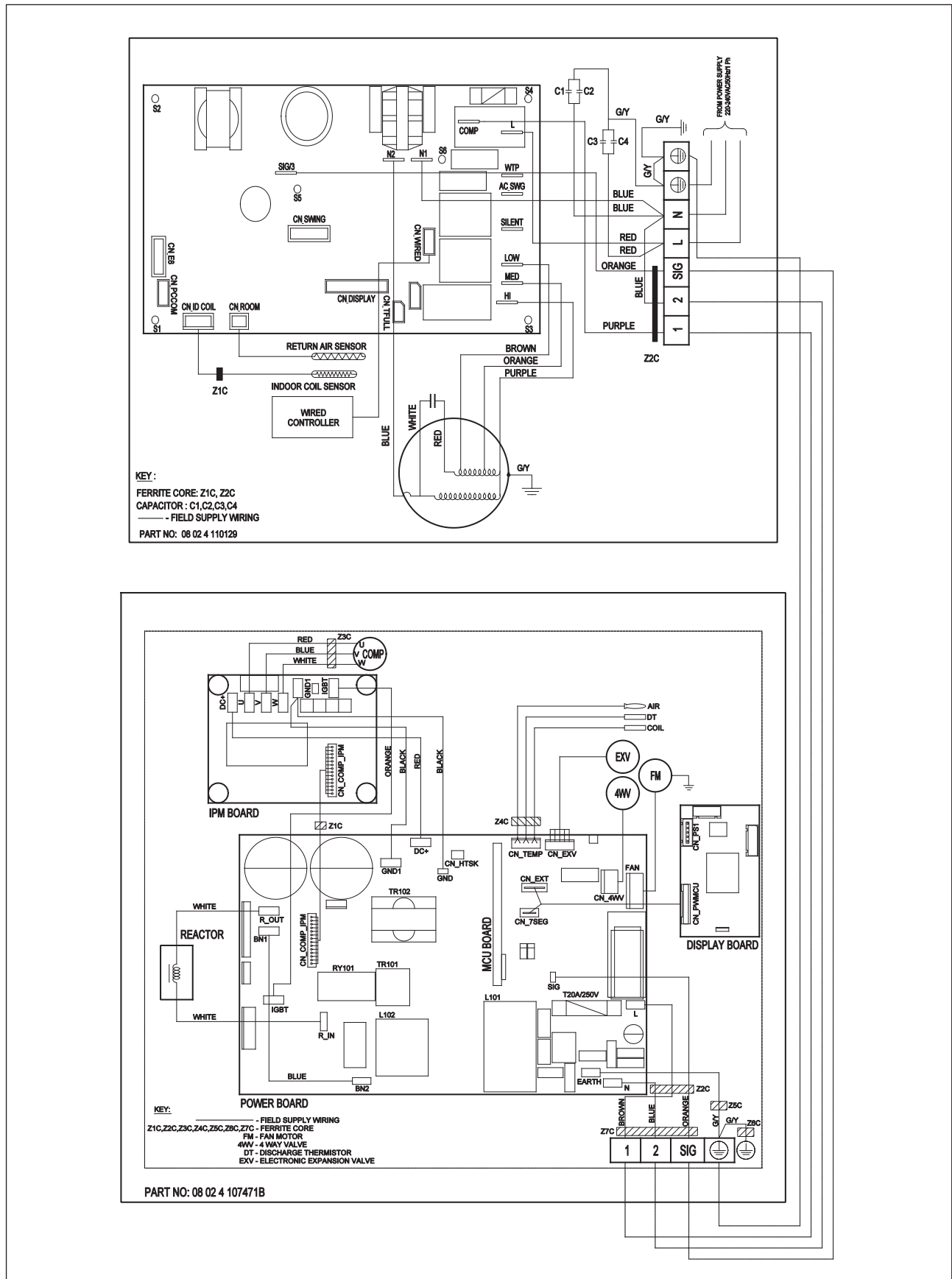

70034110366

Heat Pump

Outdoor Unit
Model: M5LCY 15DR

Indoor Unit
Model: M5CMY 15ER

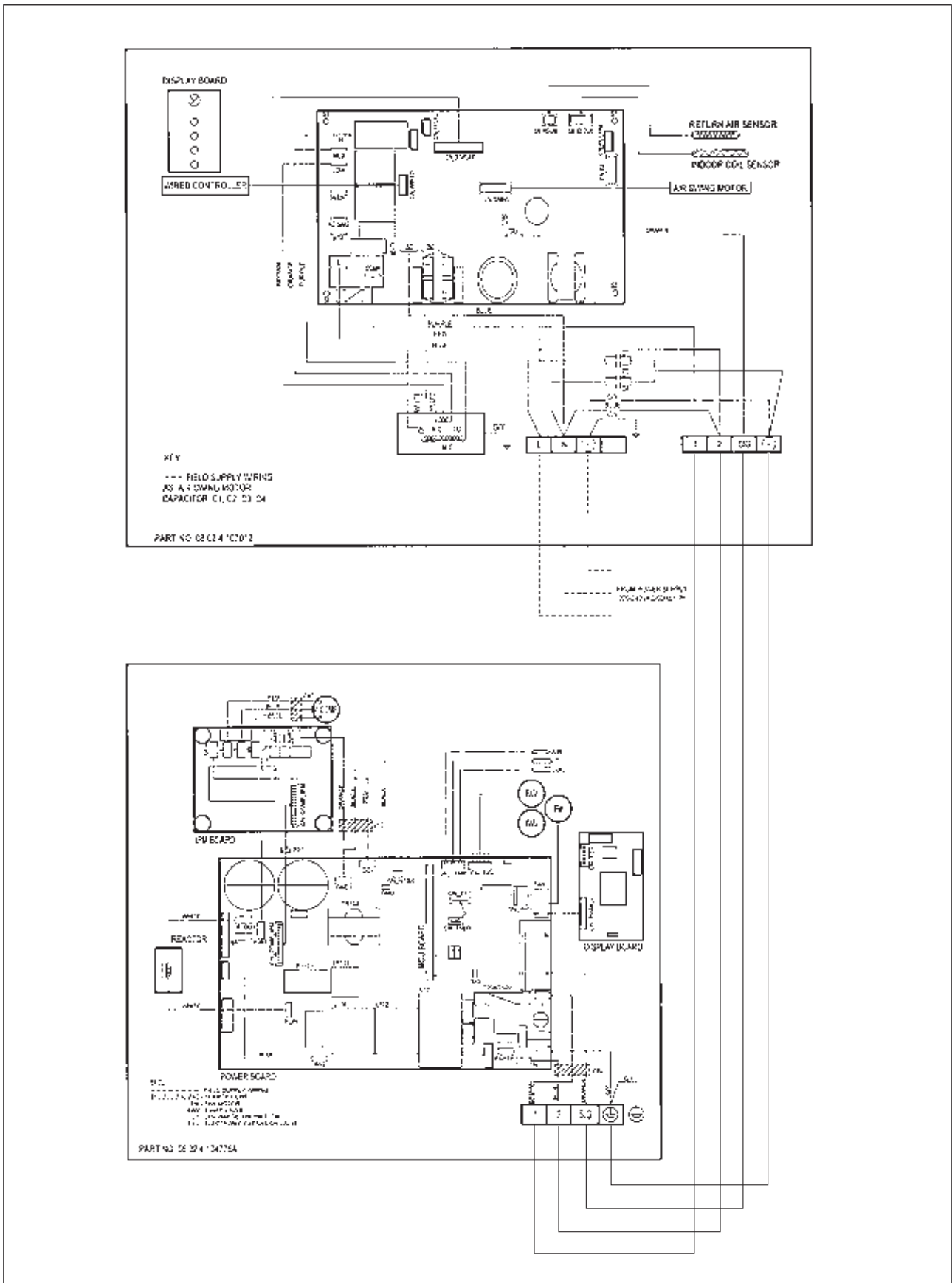

70034108591

Heat Pump

Outdoor Unit
Model: M5LCY 20/25CR

Indoor Unit
Model: M5CMY 20/25ER

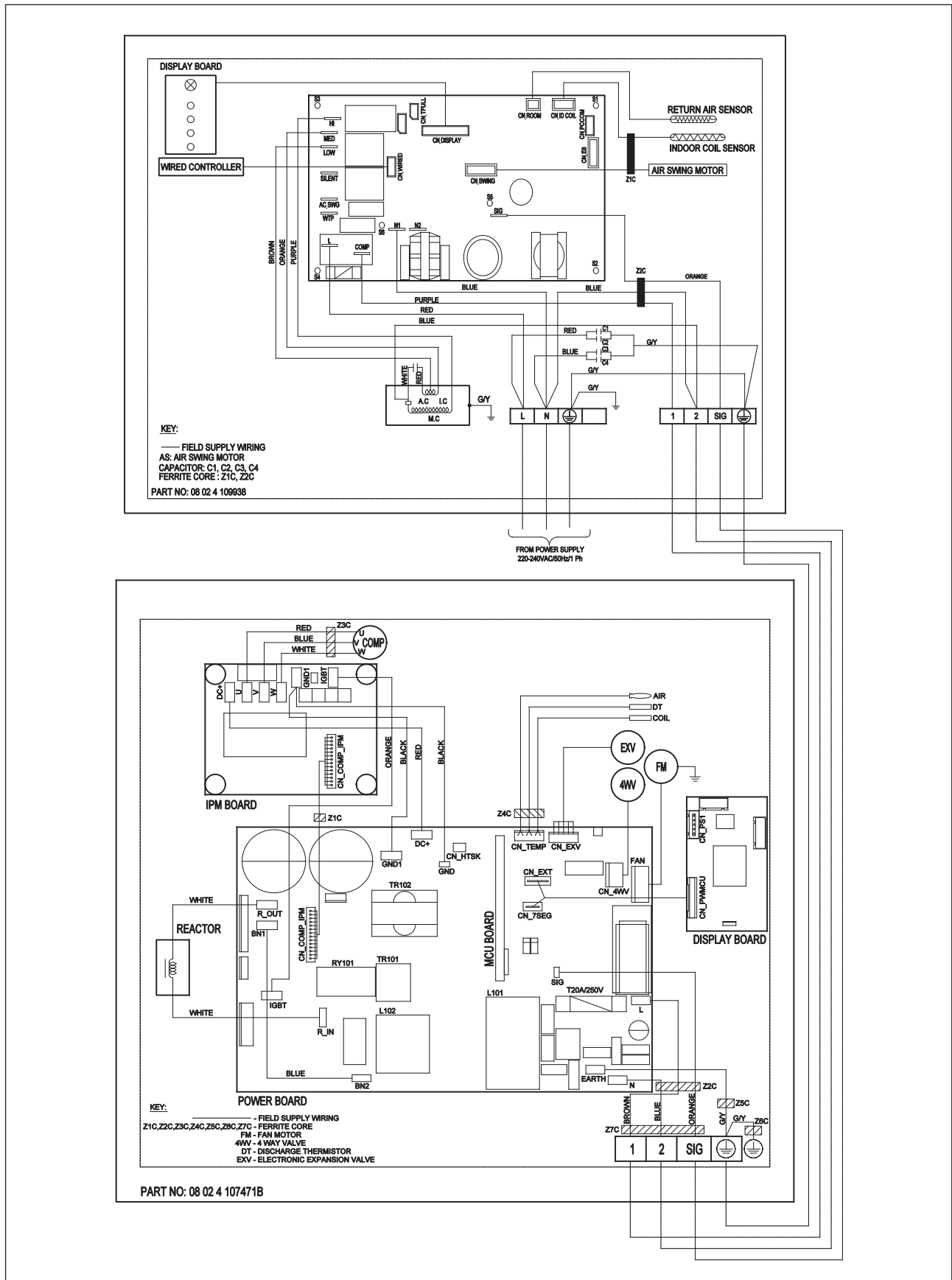

70034110365

Service and Maintenance

Warning

- Disconnect from main supply before servicing the air conditioner.
- The unit is designed to give long life operation with minimum maintenance required. However, it should be regularly checked and the following items should be given due attention.

Components	Maintenance Procedures	Period
Air Filter (Indoor Unit)	<ol style="list-style-type: none"> 1. Remove any dust adhering to the filter by using a vacuum cleaner or wash in lukewarm water (below 40°C) with a neutral cleaning detergent. 2. Rinse the filter well and dry before placing it back onto the unit. 3. Note: Never use gasoline, volatile substances or chemicals to clean the filter. 	At least once every 2 weeks. More frequently if necessary.
Indoor Unit	<ol style="list-style-type: none"> 1. Clean any dirt or dust on the grille or panel by wiping it with a soft cloth soaked in lukewarm water (below 40°C) and a neutral detergent solution. 2. Note: Never use gasoline, volatile substances or chemicals to clean the indoor unit. 	At least once every 2 weeks. More frequently if necessary.
Condense Drain Pan & Pipe	<ol style="list-style-type: none"> 1. Check the cleanliness and clean it if necessary. 2. Check the condensate water flow. 	Every 3 months.
Indoor Fan	Check if there is any abnormal noise.	If necessary.
Indoor / Outdoor Coil	<ol style="list-style-type: none"> 1. Check and remove the dirt between the fins. 2. Check and remove any obstacles which hinder air flow through the indoor or outdoor. 3. Note: Avoid direct contact of any coil treatment material on the plastic part. This may cause plastic part to deform as a result of chemical reaction. 	Every month.
Power Supply	<ol style="list-style-type: none"> 1. Check the running current and voltage for indoor and outdoor unit. 2. Check the electrical wiring and tighten the wire onto the terminal block if necessary. 	Every 2 months. Every year.
Compressor	No maintenance needed if refrigerant circuit remains sealed. However, check for refrigerant leak at joint and fitting.	Every 6 months.

Indoor Models

1. Open the front panel
 - Hold the panel at the recesses on the main unit (2 recesses on right and left sides) and lift it until it stops.
2. Remove the front panel
 - While lifting the front panel further, slide it to the right and pull it to the front side. The left rotating shaft is detached. Slide the right rotating shaft to the left and pull it to the front side to remove it.
3. Attach the front panel
 - Align the right and left rotating shafts of the front panel with the grooves and push them all the way in.
 - Gently close the front panel. (Push both ends and the center on the front panel.)

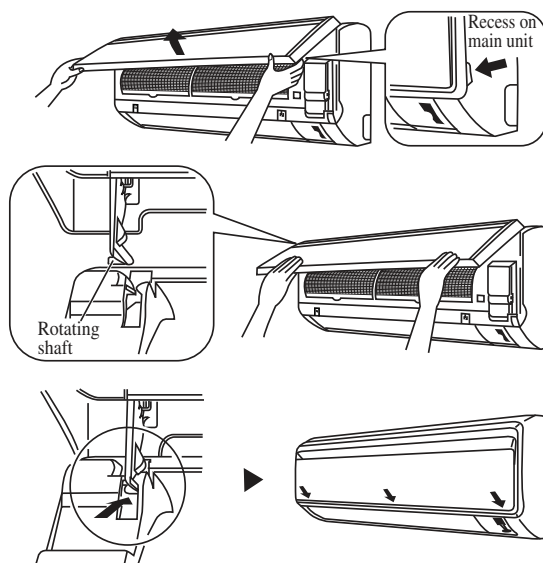

Air Filter

1. Open the front panel.
 - Hold the panel at the recesses on the main unit (2 recesses on right and left sides) and lift it until it stops.

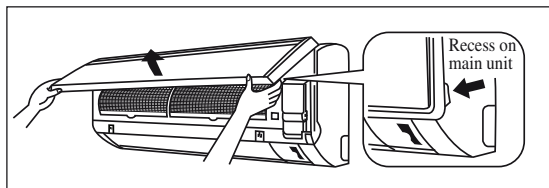

2. Pull out the air filters.
 - Push a little upwards the tab at the center of each air filter, then pull it down.
3. Clean or replace each filter.
 - When shaking off remaining water, do not wring the filter.
4. Set the air filter and close the front panel.
 - Insert claws of the filters into slots of the front panel. Close the front panel slowly and push the panel at the 3 points. (1 on each side and 1 in the middle.)
 - The air filter have a symmetrical form in the horizontal direction.

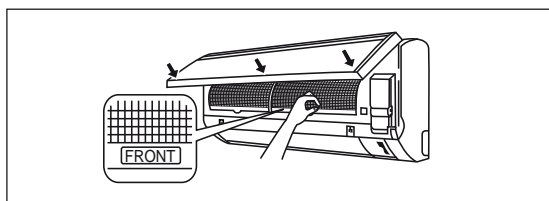

Caution

- Don't touch the metal parts of the indoor unit. It may cause an injury.
- When removing or attaching the front panel, use a robust and stable stool and watch your steps carefully.
- When removing or attaching the front panel, support the panel securely with hand to prevent from it falling.
- For cleansing, do no use hot water above 40°C, benzene, gasoline, thinner, nor other volatile oils, polishing compound, scrubbing brushes, nor other hand stuff.
- After cleaning, make sure that the front panel is securely fixed.

Pre Start Up Maintenance (After Extended Shutdown)

- Inspect thoroughly and clean indoor and outdoor units.
- Clean or replace air filters.
- Clean condensates drain line.
- Clean clogged indoor and outdoor coils.
- Check fan imbalance before operation.
- Tighten all wiring connections and panels.
- Check for refrigerant leakage.

Outdoor Models

The design of the M5LCY outdoor series allows servicing to be carried out easily. The removal of the top, front and side panels makes almost every part accessible.

Under normal circumstances, these outdoor units only require a check and cleaning of air intake coil surface once every 3 months. However, if a unit is installed in areas subjected to much oil mist and dust, the coils must be regularly cleaned by qualified Air Conditioner Service Technicians to ensure sufficient heat exchange and proper operation. Otherwise, the systems life span may be shortened.

Caution

- Do not charge OXYGEN, ACETYLENE OR OTHER FLAMMABLE and poisonous gases into the unit when performing a leakage test or an airtight test. These gases could cause severe explosion and damage if exposed to high temperature and pressure.
- It is recommended that only nitrogen or refrigerant be charged when performing the leakage or airtight test.

Troubleshooting

Fault Condition

When a malfunction of the air conditioner unit is detected, immediately switch off the main power supply before proceeding with the following troubleshooting procedures.

The following are common fault conditions and simple troubleshooting tips. If any other fault conditions which are not listed occur, contact your nearest local dealer. DO NOT attempt to troubleshoot the unit by yourself.

No	Fault conditions	Possible causes / corrective actions
1	The air conditioner unit will not resume after power failure.	<ul style="list-style-type: none"> The auto restart function is not functioning. Please turn on the unit with the wireless / wired controller.
2	The airflow is too slow or room cannot be cooled sufficiently.	<ul style="list-style-type: none"> The air filter is dirty. The doors and windows are opened. The air suction and discharge of both indoor and outdoor units are clogged or blocked. The regulated temperature or temperature setting is not low enough.
3	Discharge airflow has bad odor.	<ul style="list-style-type: none"> Cigarettes, smoke particles, perfume and others, which might have adhered onto the coil, may cause odor. Contact your nearest dealer.
4	Condensation on the front air grille of the indoor unit.	<ul style="list-style-type: none"> This is caused by air humidity after an extended period of operation. The set temperature is too low. Increase the temperature setting and operate the unit at high fan speed.
5	Water flowing out from the air conditioner.	<ul style="list-style-type: none"> Switch off the unit and contact your nearest dealer. This might be due to tilted installation.
6	Hissing airflow sound from the air conditioner unit during operation.	<ul style="list-style-type: none"> Liquid refrigerant flowing into the evaporator coil.
7	The wireless controller display is dim.	<ul style="list-style-type: none"> The batteries are discharged. The batteries are not correctly inserted. The assembly is not good.
8	Compressor operates continuously.	<ul style="list-style-type: none"> Dirty air filter. Clean the air filter. Temperature setting too low (cooling). Use higher temperature setting. Temperature setting too high (heating), Use lower temperature setting.
9	No cool air comes out during cooling cycle, or no hot air comes out during heating cycle.	<ul style="list-style-type: none"> Temperature setting too high (cooling). Use lower temperature setting. Temperature setting too low (heating). Use higher temperature setting.
10	On heating cycle, warm air does not come out.	<ul style="list-style-type: none"> Unit is in defrost mode. Heating operation will resume after defrost cycle ends.

Indicator Lights

IR Signal Receiver

When an infrared remote control operating signal has been transmitted, the signal receiver on the indoor unit will respond as below to confirm acceptance of the signal transmission.



ON to OFF	1 Long Beep
OFF to ON Pump down/Cool force on	2 Short Beep
Others	1 Short Beep

Heat Pump Unit

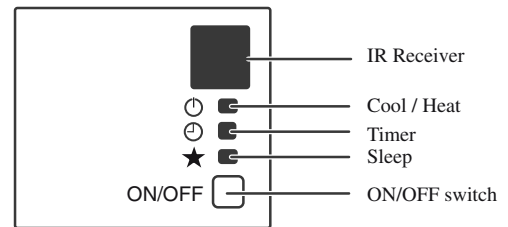
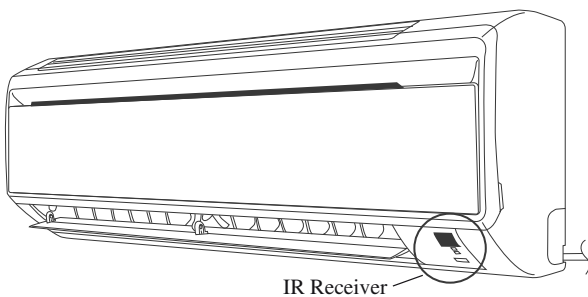
The table shows the LED indicator lights for the air conditioner unit under normal operation and fault conditions. The LED indicator lights are located at the side of the air conditioner unit. The heat pump units are equipped with an “auto” mode sensor whereby it will provide reasonable room temperature by switching automatically to either “cool” or “heat” mode according to the temperature set by the user.



LED Indicator Lights: Normal Operation and Fault Conditions for Heat Pump Unit

 SLEEP (RED)	 COOL/HEAT (GREEN/RED)	 TIMER (YELLOW)	Normal Operation / Fault Indication
	○ Green		Cool mode
	○ Red		Heat mode
	○ Red		Auto mode in Heating operation
	○ Green		Auto mode in Cooling operation
	○	○	Time off (when unit is on)
		○	Time on (when unit is off)
○	○		Sleep mode on
	○ Green		Fan mode on
	○ Green		Dry mode on
	◐ Red		Defrost operation
	◐ Green		Error indication

○ ON ◐ Blinking

Error Code Diagnosis by Wireless Handset GS01



Diagnosis Step

1. Hold down ON TIMER CANCEL button or OFF TIMER CANCEL button for 5 seconds, a “00” indication flashes on the temperature display section.
2. Press ON TIMER CANCEL or OFF TIMER CANCEL repeatedly until indoor buzzer produces a long beep. This indicates the error code, refers to Error Codes table and is displayed on the temperature display section.
3. A short beep or two consecutive beeps indicate non-corresponding error codes.
4. To cancel the error code display, hold down ON TIMER CANCEL or OFF TIMER CANCEL button for 5 seconds. Alternatively, the code display will cancel itself if the button is not pressed for 1 minute.

Error Code Diagnosis by Unit Last State Memory Using Wireless Handset

1. Remove battery from wireless handset.
2. Wait for the display to finally go off (as this handset uses very small amount of power, hence it takes longer for the memory to reset).
3. Replace battery again and immediately (before display comes back on the LCD screen), press on Mode and ON/OFF buttons together until you see “00” is being displayed.
4. Press Mode button to 5:00.
5. Press ON/OFF button once.
6. After that, remove battery from wireless handset and wait until the display has gone off. Then, replace battery again into the handset.
7. Finally, repeat the fault diagnosis steps by wireless handset GS01 above.

Error Code Diagnosis by Wired Handset Network 3C

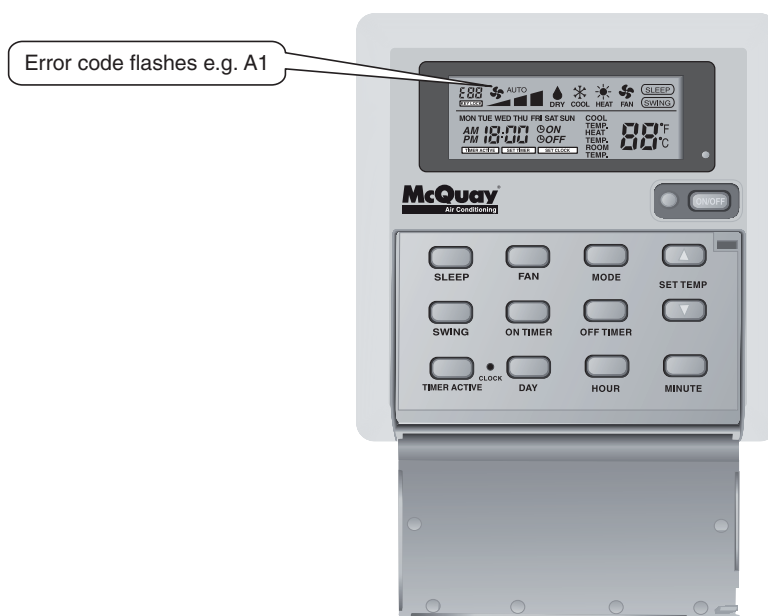

Error display using normal running

Error Code Diagnosis by Unit Last State Memory Using Wired Handset

1. Press SLEEP and TIMER ACTIVE buttons together until error code starts flashing on the fan speed indicator area.

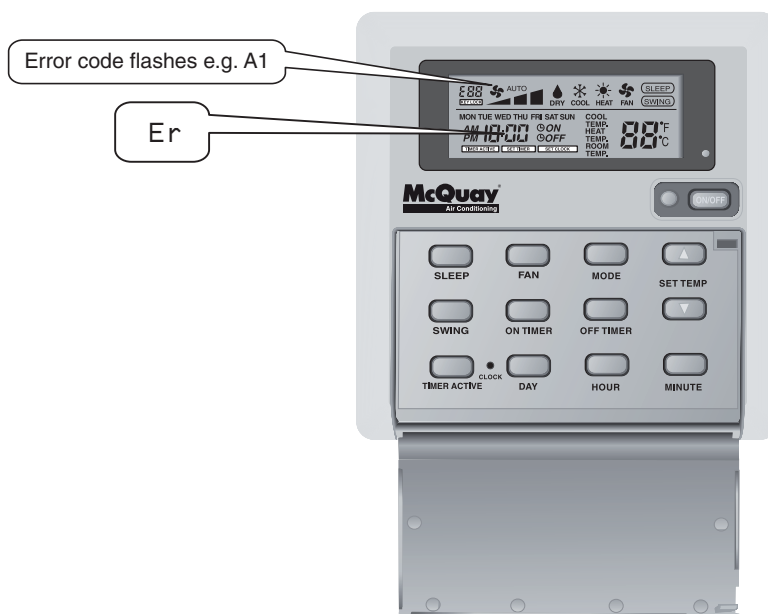

Error display using unit last state memory

Error Codes

Error Codes	Error Description	Action
0	Normal	No action.
U0	Insufficient gas	<ol style="list-style-type: none"> 1. Check sensor connection. 2. Check stop valve. 3. Check for gas leak. 4. Check the EXV. 5. Check H8.
U2	DC voltage out of range	<ol style="list-style-type: none"> 1. Check the supply voltage. 2. Check the outdoor fan by rotating with hand. 3. Restart the system. 4. Check power supply waveform.
U4	Communication error	<ol style="list-style-type: none"> 1. Check the indoor unit - outdoor unit connection wires. 2. Check the voltage of the signal terminal. 3. Check the indoor fan by rotating with hand. 4. Check the power supply waveform.
U7	Signal transmission error (on outdoor unit PCB)	<ol style="list-style-type: none"> 1. Restart the system. 2. Replace outdoor PCB. 3. Long term monitor on external factor.
UA	Installation error	<ol style="list-style-type: none"> 1. Check the indoor and outdoor unit model name. 2. Check the part code on the indoor and outdoor PCB.
UF	Communication Error (indoor and outdoor) piping and wiring	<ol style="list-style-type: none"> 1. Check the wiring and piping between indoor and outdoor units. 2. Check refrigerant level. 3. Check refrigerant line on blockage.
UH	Anti-freeze function in other room	<ol style="list-style-type: none"> 1. Check which indoor having error A5. 2. Check the supply voltage. 3. Check the indoor and outdoor model name.
A1	Indoor PCB error	<ol style="list-style-type: none"> 1. Check connector connection. 2. Replace indoor PCB.
A3	Water pump error	<ol style="list-style-type: none"> 1. Check for short circuit. 2. Check connection on drain pump. 3. Restart the system. 4. Check the drain water level. 5. Check float switch connection.
A5	Antifreeze	<ol style="list-style-type: none"> 1. Check the air passage. 2. Check the intake air filter. 3. Check dust accumulation on indoor coil. 4. Check wiring and piping. 5. Check the EXV. 6. Check indoor coil sensor resistance value. 7. Check refrigerant level. 8. Check room sensor resistance value.
A6	Indoor fan motor abnormal	<ol style="list-style-type: none"> 1. Check the indoor fan by rotating with hand. 2. Replace indoor fan motor if not rotating smoothly. 3. Check fan motor voltage. 4. Replace indoor PCB if not at the rated voltage. 5. Check fan capacitor's conductivity (AC Motor). 6. Replace fan capacitor if there's conductivity.
C4	Indoor heat exchanger thermistor short / open	1. Check the connector connection.
C9	Indoor room thermistor short / open	2. Check the sensor resistance value.
E1	Outdoor PCB error	<ol style="list-style-type: none"> 1. Restart the system. 2. Replace outdoor PCB. 3. Check to see that the unit is grounded. 4. Check power supply waveform.

Error Codes	Error Description	Action
E3	High pressure protection	1. Check installation conditions.
		2. Check stop valve.
		3. Check HPS connection.
		4. Check pressure level by pressure gauge.
		5. Wait for 10 minutes then restart the system.
		6. Check if H3 is displayed.
E4	Low pressure protection	1. Check stop valve.
		2. Check low pressure sensor connection.
		3. Check low side pressure and voltage.
		4. Check outdoor coil sensor connection.
		5. Check sensor resistance value.
		6. Check refrigerant level.
E5	Compressor motor lock/overload	1. Check connection on discharge pipe sensor.
		2. Check discharge pipe sensor resistance value.
		3. Check the EXV.
		4. Check the refrigerant line on blockage or shortage.
E6	Compressor lock/start-up error	1. Check with inverter checker.
		2. Check the EXV.
E7	Outdoor DC fan motor lock	1. Check the fan motor connection.
		2. Check if foreign matters exist around or in the fan.
E8	Ac input over current	1. Measure the input current.
		2. Check the main circuit electrolytic capacitor.
		3. Check with inverter checker.
		4. Check discharge pressure.
		5. Check the installation condition.
E9	EXV error	1. Restart the system.
		2. Check the EXV connection.
		3. Check EXV coil resistance.
		4. Check sensors resistance value.
EA	4-way valve error	1. Check 4WV coil connection.
		2. Check the continuity of the 4WV coil and harness.
		3. Check the 4WV switching output.
		4. Check sensor connection.
		5. Check sensor resistance value.
		6. Check the refrigerant line on blockage or shortage.
F3	Discharge pipe overheat	1. Check the discharge pipe sensor.
		2. Check the EXV.
		3. Check the refrigerant line on blockage or shortage.
F6	Heat exchanger overheat	1. Check the installation space.
		2. Check the outdoor fan.
		3. Check the EXV.
		4. Check the coil sensor.
H0	Compressor sensor system abnormality	1. Check the reactor connection.
		2. Check the compressor connection.
		3. Measure the resistance value between the reactor terminals.
		4. Measure the resistance value between the compressor terminals.
H3	High pressure switch error	1. Check pressure sensor connection.
		2. Check HPS continuity.
H6	Position sensor abnormality	1. Check for short circuit.
		2. Check the electrolytic capacitor voltage.
		3. Check compressor harness wire.
		4. Check with inverter checker.

Error Codes	Error Description	Action
H8	AC current sensor error	1. Restart the system.
		2. Check capacitor voltage.
		3. Measure the rectifier input voltage.
		4. Check compressor harness wire.
		5. Check with inverter checker.
H9	Outdoor air thermistor short / open	1. Check the sensor connection.
		2. Check the sensor resistance value.
J1	Pressure sensor error	1. Check pressure sensor connection.
		2. Check pressure and voltage level.
J3	Compressor discharge pipe thermistor short / open / misplaced	1. Check the sensor connection.
		2. Check the sensor resistance value.
		3. Check indoor coil sensor resistance value.
J5	Suction pipe thermistor short / open	Same as H9.
J6	Outdoor heat exchanger	Same as H9.
J7	Subcooling heat exchanger thermistor short / open	Same as H9.
J8	Liquid pipe thermistor short / open	Same as H9.
J9	Gas pipe thermistor abnormality	Same as H9.
LC	Communication Error (control PCB and inverter PCB)	1. Check fan motor connection.
		2. Check if LED blinking normally at outdoor PCB.
L1	Outdoor PCB error	1. Check the range of power supply.
		2. Check connection between compressor and PCB.
		3. Check fan motor resistance.
		4. Check the power supply waveform.
L3	Electrical box temperature rise	1. Restart the system.
		2. Check sensor resistance value.
		3. Check heat sink temperature and conditions.
		4. Check outdoor fan.
		5. Check the installation condition.
L4	Heat sink overheat	1. Restart the system.
		2. Check the silicon grease condition on heat sink.
		3. Check sensor resistance value.
		4. Check heat sink temperature and conditions.
		5. Check outdoor fan.
		6. Check the installation condition.
L5	IPM error / IGBT error	1. Check stop valve.
		2. Check with inverter checker.
		3. Check the power transistor.
		4. Check the supply voltage.
		5. Check the compressor phase.
		6. Check the discharge pressure.
		7. Check the installation condition.
L8	Electrical thermal switch	Contact dealers for assistance.
L9	Stall prevention	1. Check installation conditions.
		2. Check stop valve.
		3. Check difference between high and low pressure side.
		4. Check continuity on the power transistor.
		5. Check the output voltage.
P1	Open phase or voltage unbalance	1. Check LED on outdoor PCB.
		2. Check open phase of power supply voltage.
		3. Check voltage balance between phases.
P4	Heat sink thermistor short / open	Same as H9.
PJ	Capacity setting error	1. Check the connection between capacitor and Outdoor PCB.

Unit Running Parameter

Parameter Number	Parameter Description	Unit/ range
00	Compressor Actual Rotation	r/s
01	Compressor Target Rotation	r/s
02	DC Bus Voltage	VDC
03	Total Current ($\div 10$)	A
04	Outdoor Air Temperature	°C
05	Outdoor Heat Exchanger Temperature	°C
06	Compressor Discharge Temperature	°C
07	Outdoor Heatsink Temperature	°C
08	Indoor Air Temperature	°C
09	Indoor Heat exchanger Temperature	°C
10	EXV Opening	Pulse
11	Outdoor fan speed	W0 ~ W6
12	Horse power	15: 1.5hp
13	Software version (Production)	
14	Software version (Development)	
15	3 minutes count up stop timer	
16	Communication stage	0~3
17	Indoor On/Off	0- Off, 1-ON
18	Delta D	
19	Running mode	0-Fan, 1- Heat, 2-Cool
20	Startup up timer	
21	Comp initial control flag ok	
22	Fuzzy control Delta H	
23	Comp freq set pointer	
24	Comp stop pointer	
25	Comp limit pointer	
26	Comp limit speed	Max r/s
27	Discharge high temp zone	0-Normal, Other-Active
28	High pressure zone	0-Normal, Other-Active
29	Current control zone	0-Normal, Other-Active
30	Oil return status	0-Normal, Other-Active
31	De-ice setting	0-Normal, Other-Active
32	Dew drop setting	0-Normal, Other-Active
33	Heatsink protection zone	0-Normal, Other-Active
34	Turbo setting	0-Normal, Other-Active
35	Silent setting	0-Normal, Other-Active
36	Low ambient zone	0-Normal, Other-Active
37	Defrost status	0-Normal, Other-Active
38	Pump down status	0-Normal, Other-Active
39	O/D capacity flag	0- Comp off, 1- Comp On
40	O/D output capacity	In %
41	Target discharge temp	
42	EXV control status	0-Initial , 1- Feedback
43	Indoor fan tap	

Parameter Number	Parameter Description	Unit/ range
44	O/D error code	
45	I/D error code	
46	Low voltage control zone	0-Normal, Other-Active
47	Gas leak detection	0-Normal, Other-Active
48	Discharge sensor disconnected	0-Normal, Other-Active
49	Official test setting	0-Normal, Other-Active
50	Skip frequency flag	0-Normal, Other-Active
51	Last O/D error code	
52	2nd last O/D error code	
53	3rd last O/D error code	

Exploded View and Part List

Outdoor Unit

Model: M5LCY 10/15DR

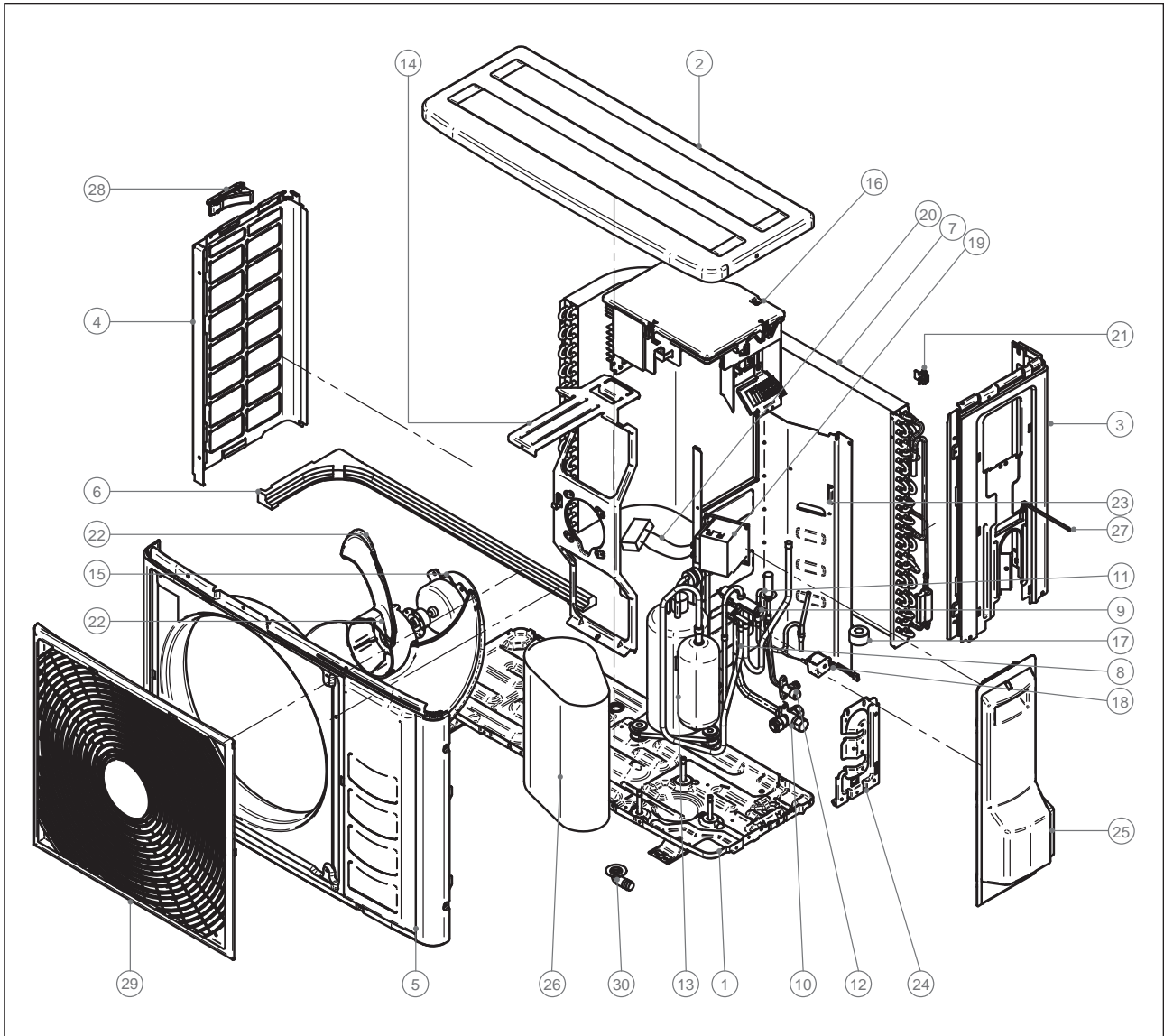

Note: All exploded view and part list are subjected to change by the manufacturer without prior notice

Outdoor Unit

Model: M5LCY 10/15DR

No	Description	No	Description
1	Assy. Botttom Frame	16	Assy. Control Box
2	Top Plate	17	EXV Solenoid Coil
3	Right Side Plate	18	Assy. 4WV Coil
4	Left Side Plate	19	Reactor
5	Front Panel	20	Assy. Reactor Wire
6	Sealing Material	21	Thermistor Holder
7	Assy. Coil	22	Assy. Propeller Fan
8	Assy. 4WV	23	Assy. Panel Partion
9	Valve, Rev 4 Way	24	Stop Valve Mounting Plate
10	Valve, 3 Way 1/2"	25	Assy. Stop Valve Cover
11	Assy. EXV w/o Service Valve	26	Ins. Comp. Sound
12	Valve, 2 Way 1/4"	27	Releasable Tie
13	Compressor	28	Handle
14	Assy. Fan Motor	29	Front Grille
15	Motor	30	Drain Joint

Note: All exploded view and part list are subjected to change by the manufacturer without prior notice

Outdoor Unit
Model: M5LCY 20/25CR

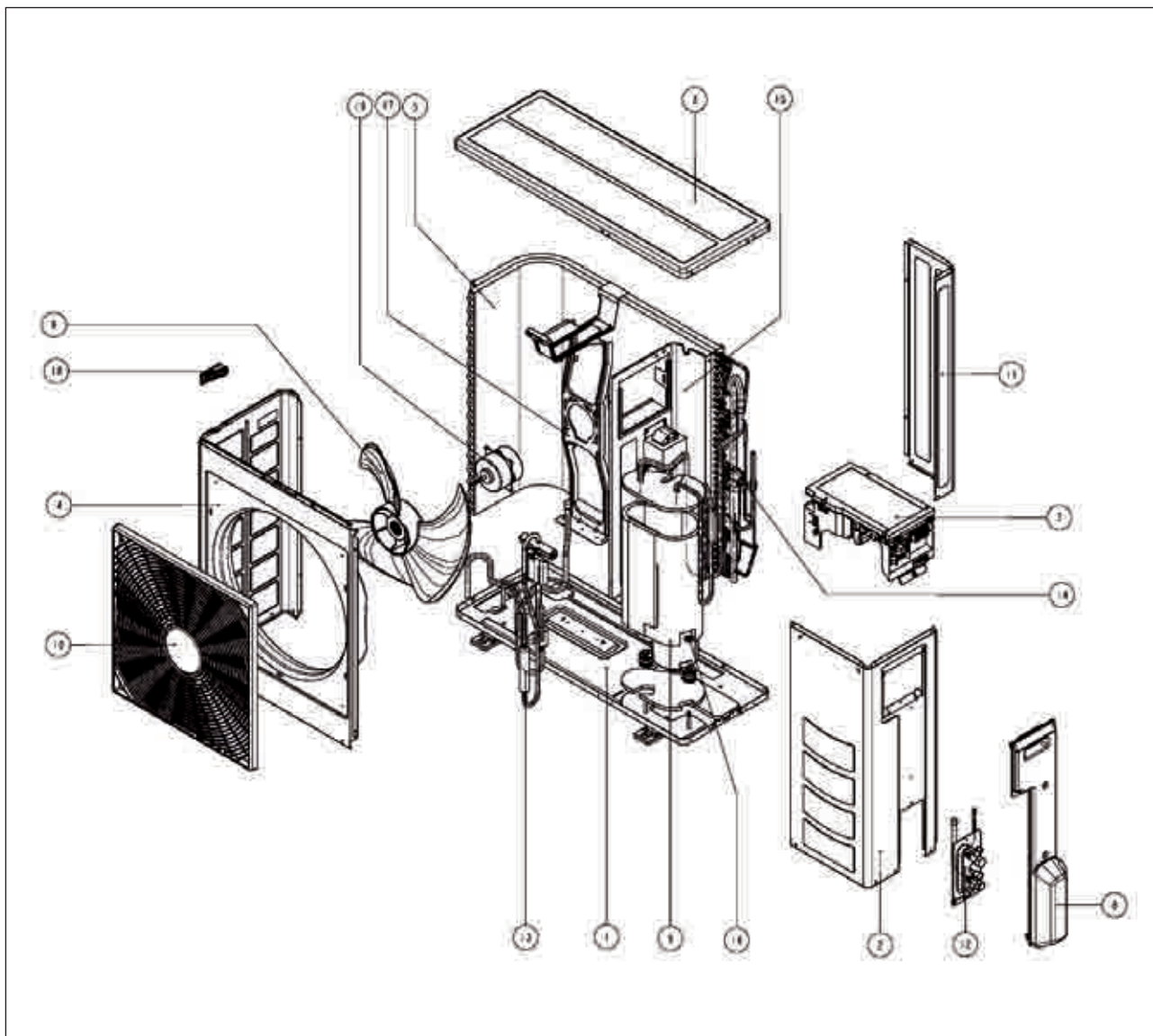

No	Description
1	Assy. Base Fan
2	Panel, Service
3	Panel, Top
4	Panel, Front/Left
5	Assy. Coil
6	Assy. Propeller Fan
7	Assy. Control Box
8	Assy. Valve Cover
9	Compressor
10	Plastic, Front Grille

No	Description
11	Panel, Right Back
12	Assy. Valve Bracket
13	Assy. 4WV
14	Assy. EXV
15	Assy. Partition
16	Nut M8, with flange
17	Bracket, Motor
18	Plastic, Handle
19	Motor

Note: All exploded view and part list are subjected to change by the manufacturer without prior notice

Indoor Unit
Model: M5WMY 10/15JR

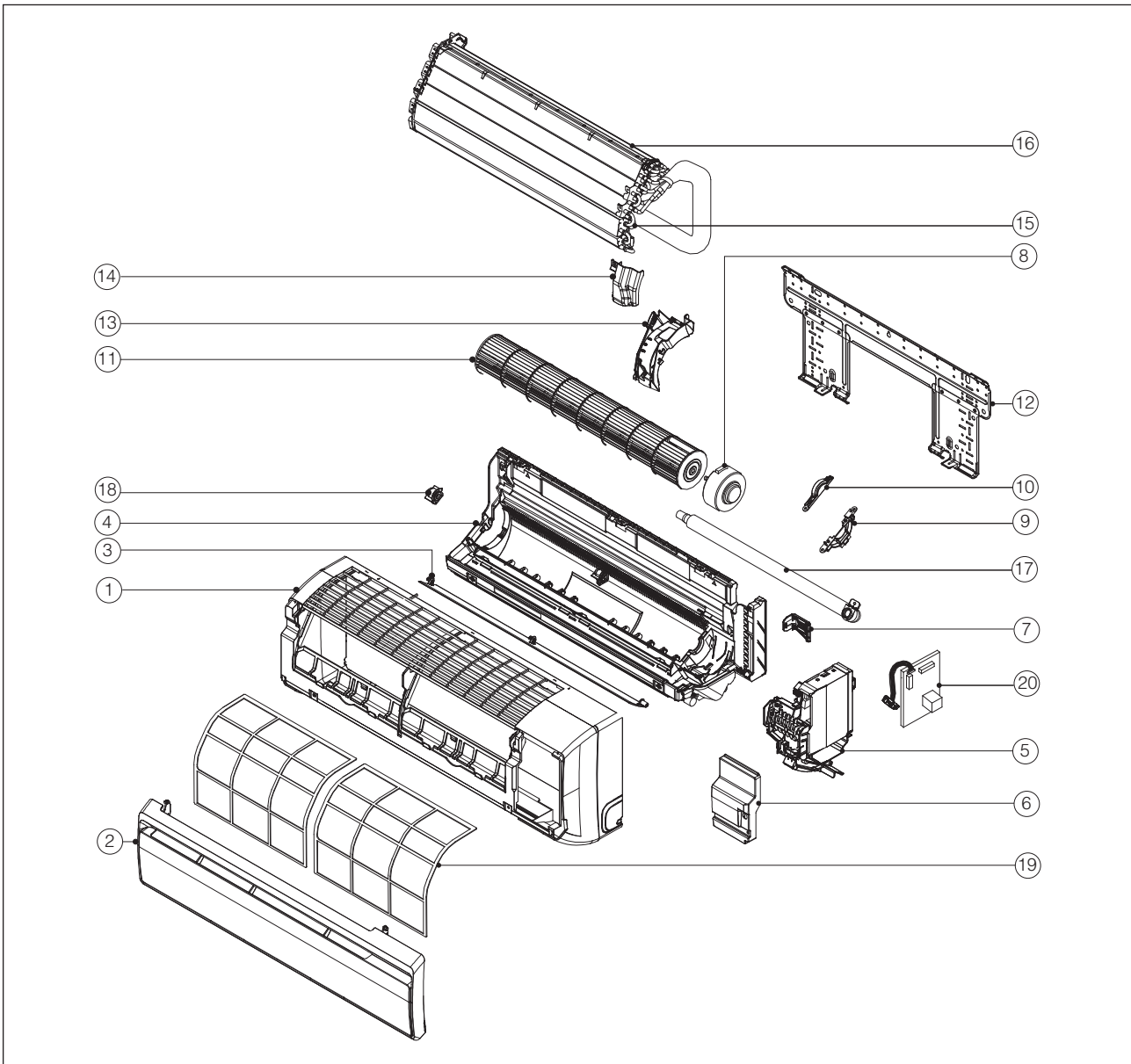

No	Description
1	Assy. Front Grille
2	Panel, McQuay
3	Disch. Grille Hor.Blade Assy.
4	Assy. Bottom Frame
5	Assy. Control Box
6	Assy. Service Cover
7	Assy. Piping Fixture
8	Motor
9	Motor Mounting Plate (1)
10	Motor Mounting Plate (2)

No	Description
11	Blower
12	Assy. Installation Plate
13	Right Side Panel
14	Cover, Drip Proof
15	Clip, Coil Sensor
16	Assy. Heat Exchanger
17	Assy. Drain Hose
18	Fan Bearing Vibration Absorber
19	Air Filter
20	Assy. Control Module

Note: All exploded view and part list are subjected to change by the manufacturer without prior notice

Indoor Unit
Model: M5WMY 20/25JR

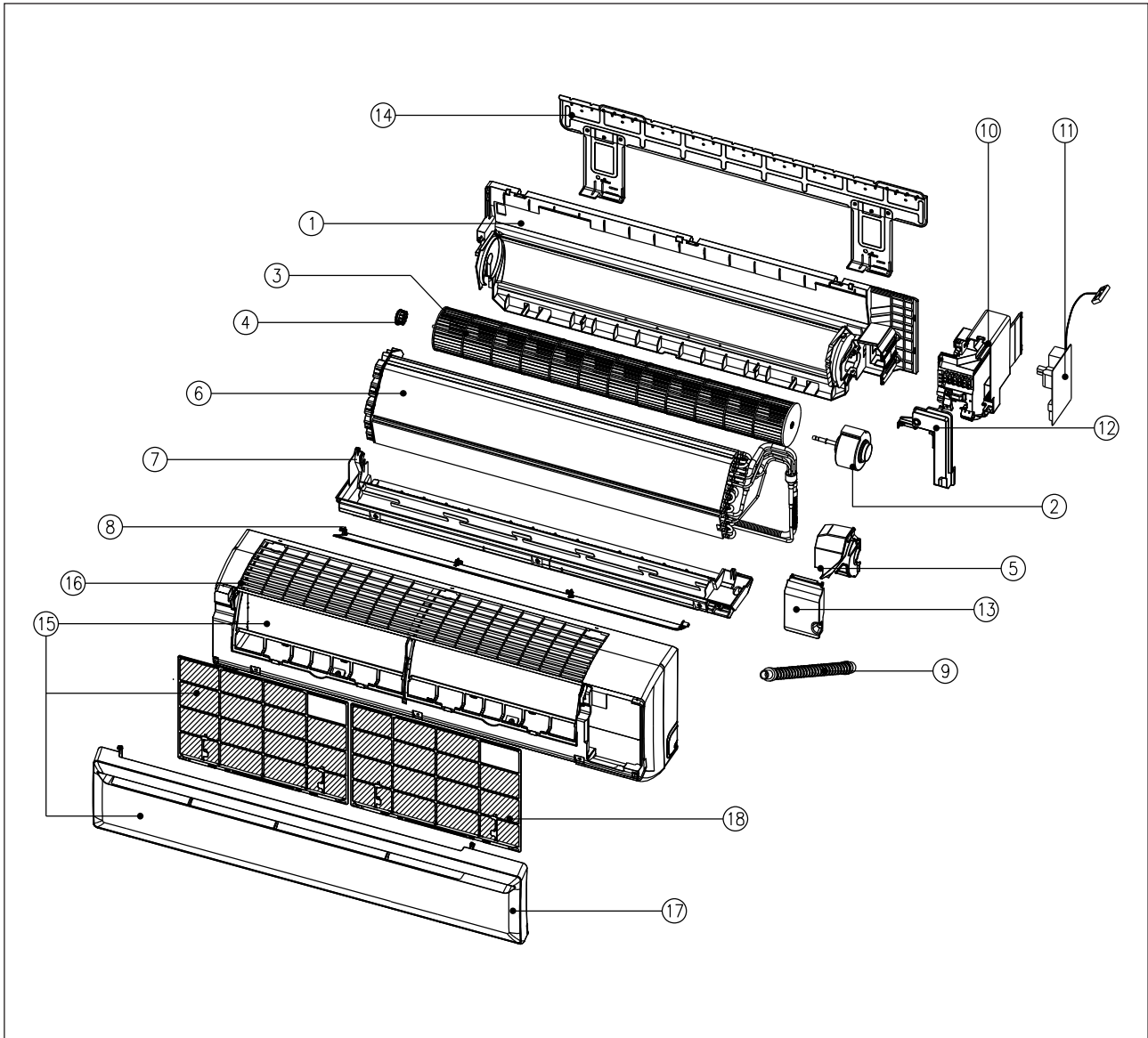

No	Description
1	Assy. Chasis
2	Motor
3	Blower
4	Fan Bush
5	Cover, Motor
6	Assy. Heat Exchanger
7	Assy. Air Discharge Housing
8	Assy. Louver
9	Hose

No	Description
10	Assy. Control Box
11	Assy. Control Module
12	Cover, Control Box
13	Cover, Service
14	Assy. Mounting Plate
15	Assy. Front Cover
16	Cover, Front
17	Intake Grille
18	Filter

Note: All exploded view and part list are subjected to change by the manufacturer without prior notice

Indoor Unit
Model: PLCKY-CR

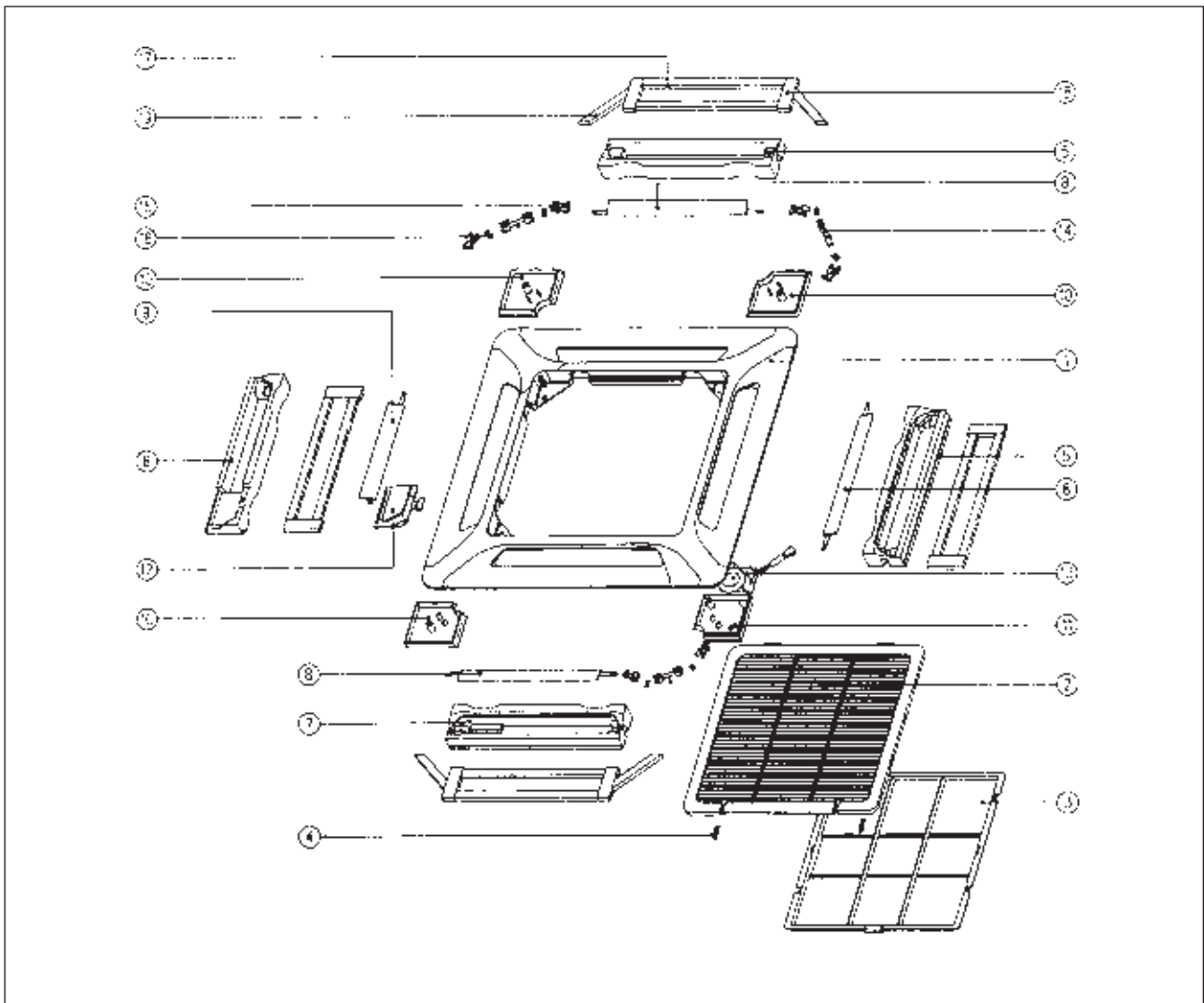

No	Description
1	Frame
2	Assy. Intake Grille B
3	Filter
4	Lock, Grille
5	Discharge, Foam
6	Discharge, Foam LED
7	Discharge, Foam Short
8	Louver
9	Louver, LED
10	Lingkage, Cover

No	Description
11	Lingkage, Motor Cover
12	Assy. Bracket Receiver (LED/SLM)
13	Assy. Motor
14	Crank, Connector
15	Louver, Holder
16	Cross, Crank
17	Ins. Long
18	Ins. Short
19	Ins. Corner

Note: All exploded view and part list are subjected to change by the manufacturer without prior notice

Indoor Unit
Model: M5CKY 10/15/20CR

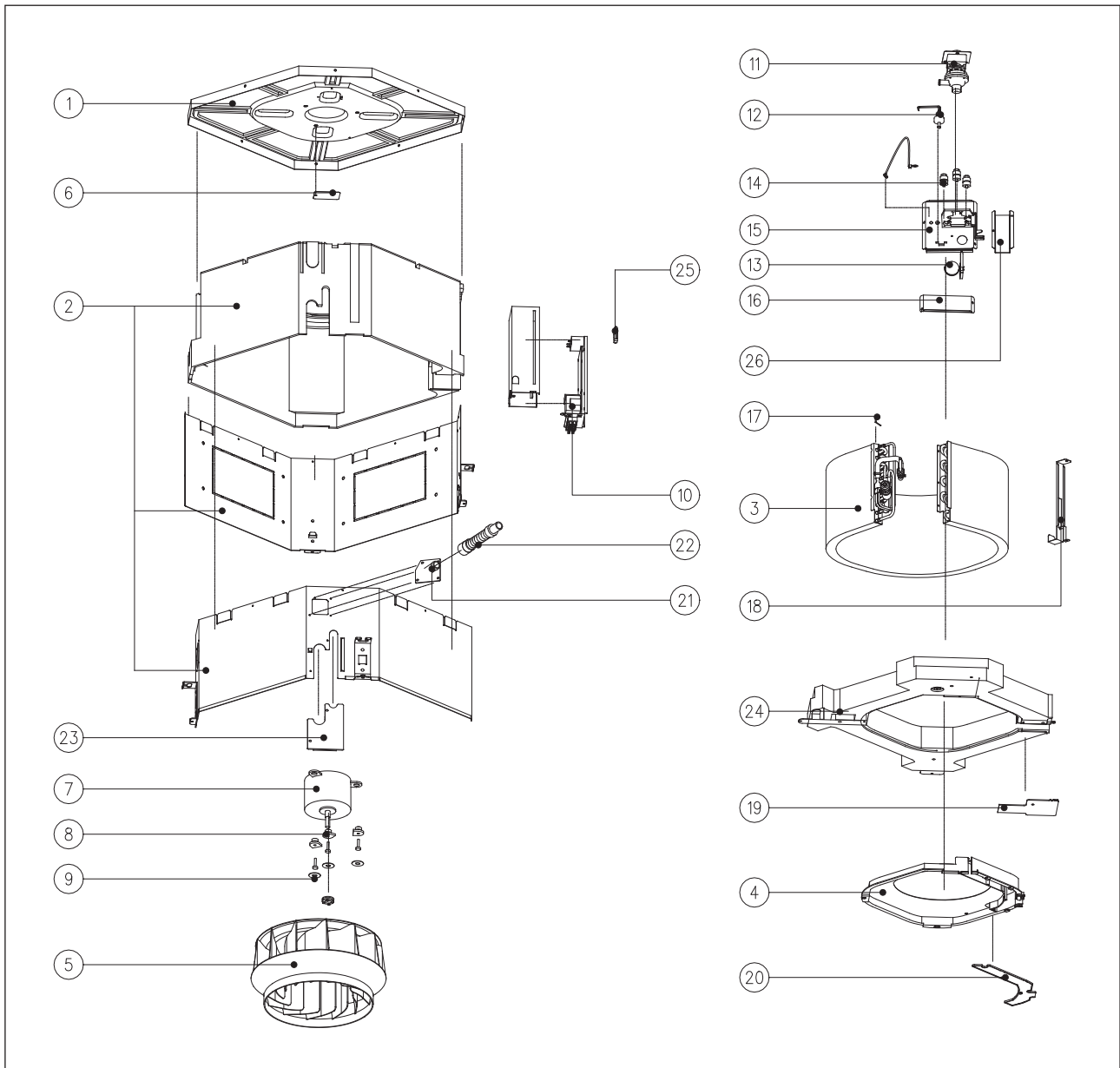

Note: All exploded view and part list are subjected to change by the manufacturer without prior notice

Indoor Unit
Model: M5CKY 10/15/20CR

No	Description
1	Assy. Base
2	Assy. Casing
3	Assy. Heat Exchanger
4	Cover, Fan
5	Blower
6	Plate, Wire
7	Motor
8	Bush, Motor
9	Bush, Motor Ring
10	Assy. Control Box
11	Pump, Water
12	Switch, Water Level
13	Bush, Wire

No	Description
14	Bush, Pump
15	Assy. Drain Pump Support Bracket
16	Assy. End Plate Support
17	Clip, Coil Sensor
18	Support, Heat Exchanger
19	Cover, Terminal
20	Assy. Cover Wire
21	Connector, Drain
22	Hose, Drain
23	Assy. Cover Valve
24	Assy. Drain Pan
25	Bush, Wire
26	Cover, Wire Bracket

Note: All exploded view and part list are subjected to change by the manufacturer without prior notice

Indoor Unit
Model: PLCKY-ER

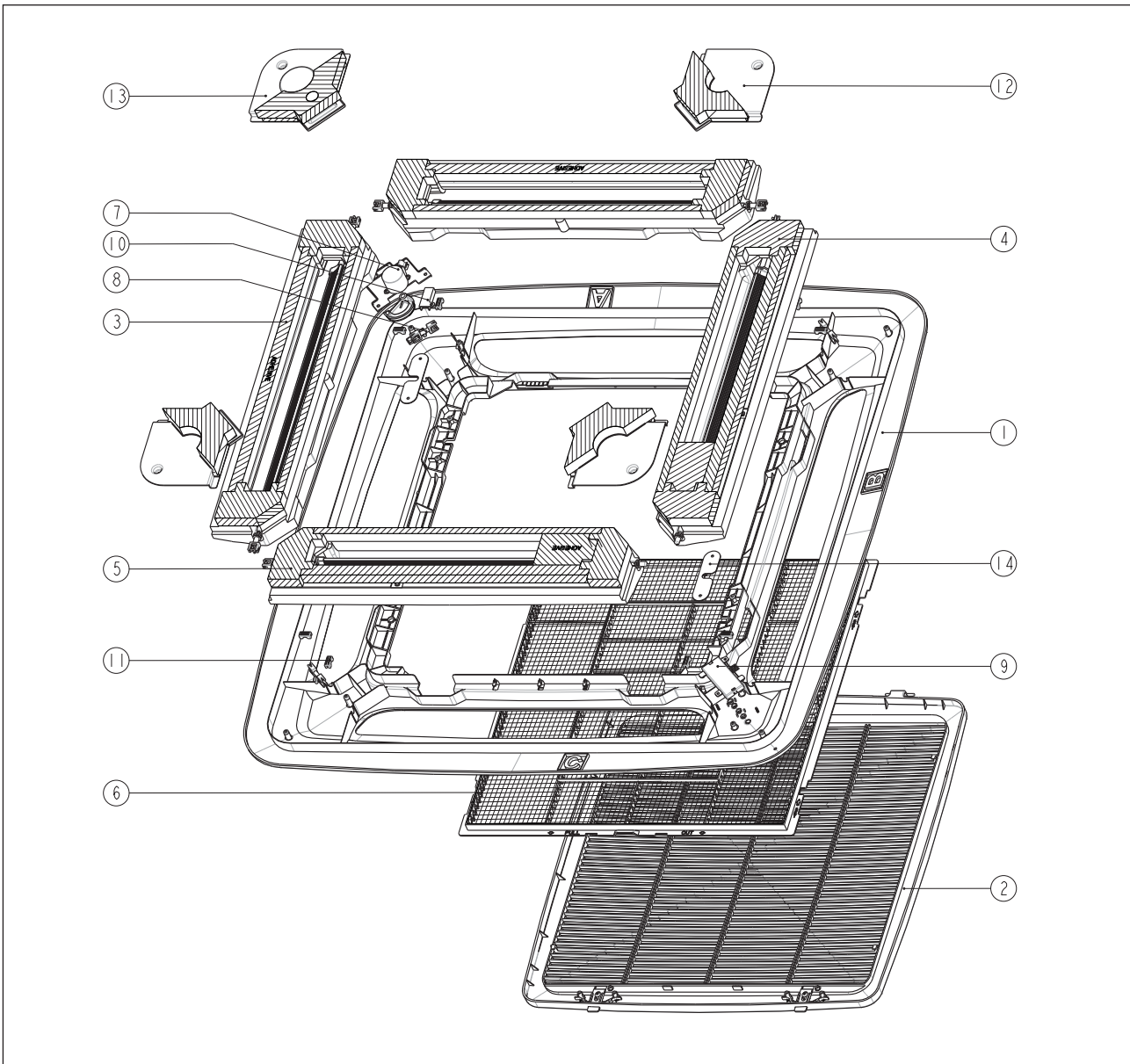

No	Description
1	Front, Frame
2	Assy. Intake Grille
3	Assy. Air Discharge Main
4	Assy. Air Discharge Main Right
5	Assy. Air Discharge Main Left
6	Air Filter, CK-A/AR
7	Assy. Air Swing Motor

No	Description
8	Crank Connector
9	Assy. LED
10	Wire, Guide
11	Cover, Cross Connector
12	Assy. Cover Corner A
13	Assy. Cover Corner B
14	Mounting Plate

Note: All exploded view and part list are subjected to change by the manufacturer without prior notice

Indoor Unit

Model: M5CKY 20/25ER

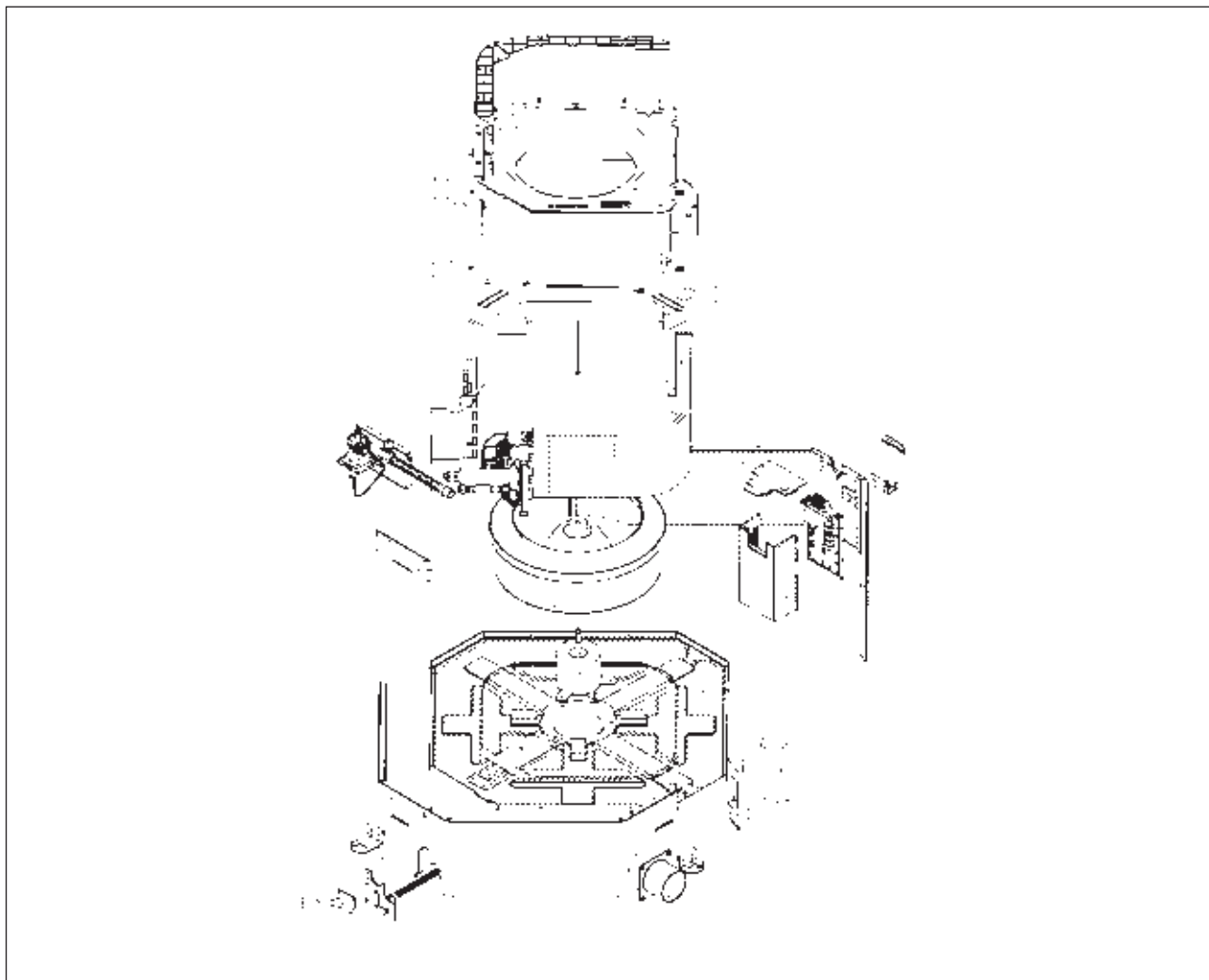

No	Description
1	Assy. Base Pan
2	Assy. Coil
3	Assy. Coil Bracket
4	Assy. Drain Pump Mounting
5	Assy. Panel Side Back
6	Assy. Side Panel Front
7	Assy. Motor & Rubber
8	Blower, Turbo Fan DIA462 X 171.5 3P085496-1
9	Assy. Drain Pan
10	Assy. Fan Cover
11	Assy. Cover Control Box
12	Assy. Control Box
13	Assy. Cover Terminal
14	Support, Coil
15	Cover, Wire A

No	Description
16	Cover, Wire B
17	Bracket, Hanger A
18	Bracket, Hanger B
19	Bracket, Hanger C
20	Fresh Air Adaptor
21	Assembly, Valve Plate
22	Assy. Air Guide
23	Assy. Partition Holder
24	Cover, Wire
25	Switch Water Level 1A - CK Drain Pump
26	Pump, Water PC-04226-OYOB YCK
27	Hose, Drain PE 18.3 X 0.5 X 315.0
28	Connector, Drain
29	Ins., Drain Connector

Note: All exploded view and part list are subjected to change by the manufacturer without prior notice

Indoor Unit
Model: M5CCY 10/15/20/25CR

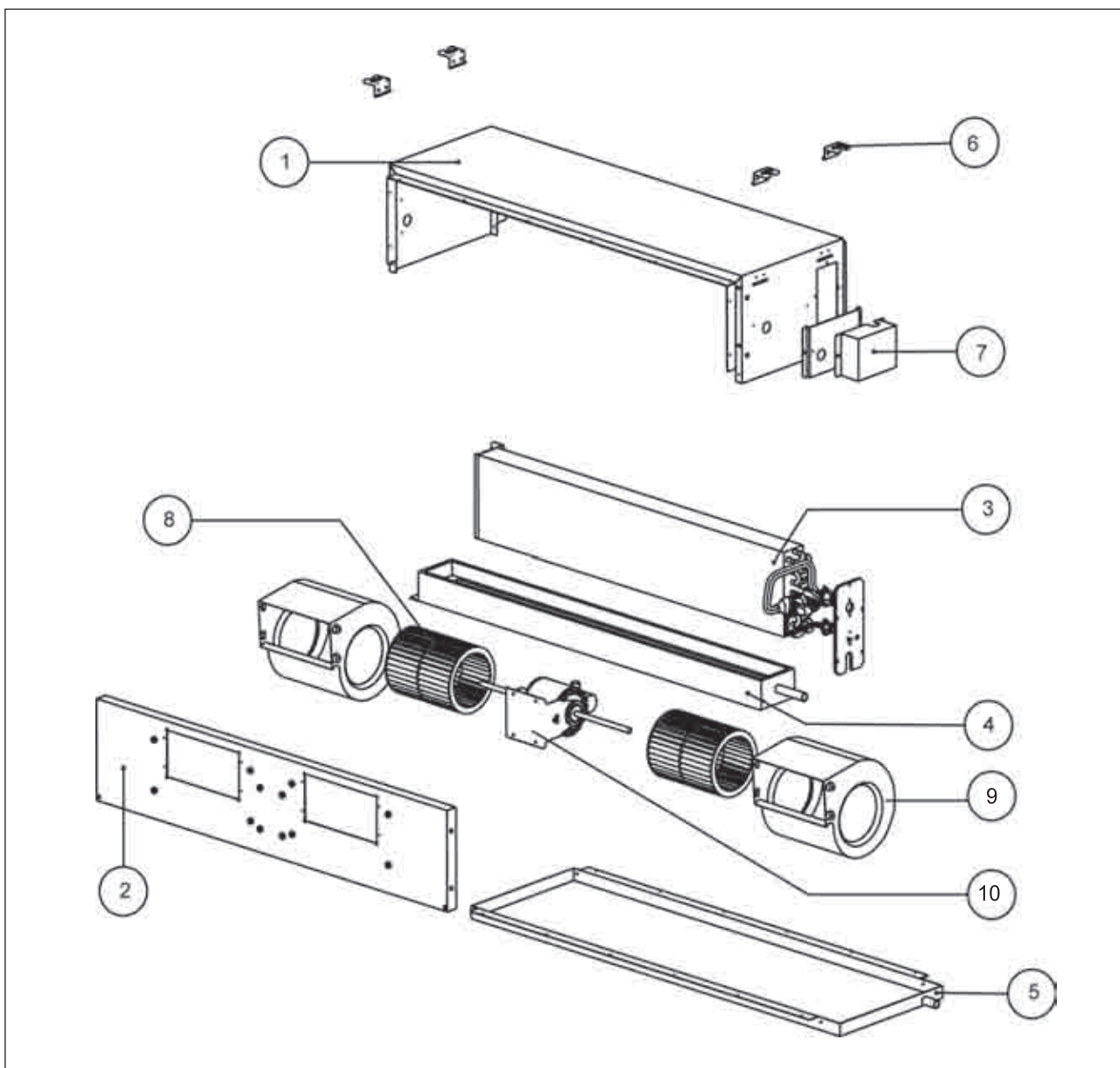

No	Description
1	Cabinet
2	Assy. Fan Deck
3	Assy. Heat Exchanger
4	Assy. Drain Pan
5	Assy. Secondary Drain Pan
6	Hanger
7	Control Module
8	Assy. Blower Right

No	Description
9	Assy. Blower Left
10	Motor
Parts Not in Diagram	
	Handset, Wired
	Air Filter
	Holder, Thermistor
	Clip, Coil Sensor

Note: All exploded view and part list are subjected to change by the manufacturer without prior notice

Indoor Unit
Model: M5CMY 15/20/25ER

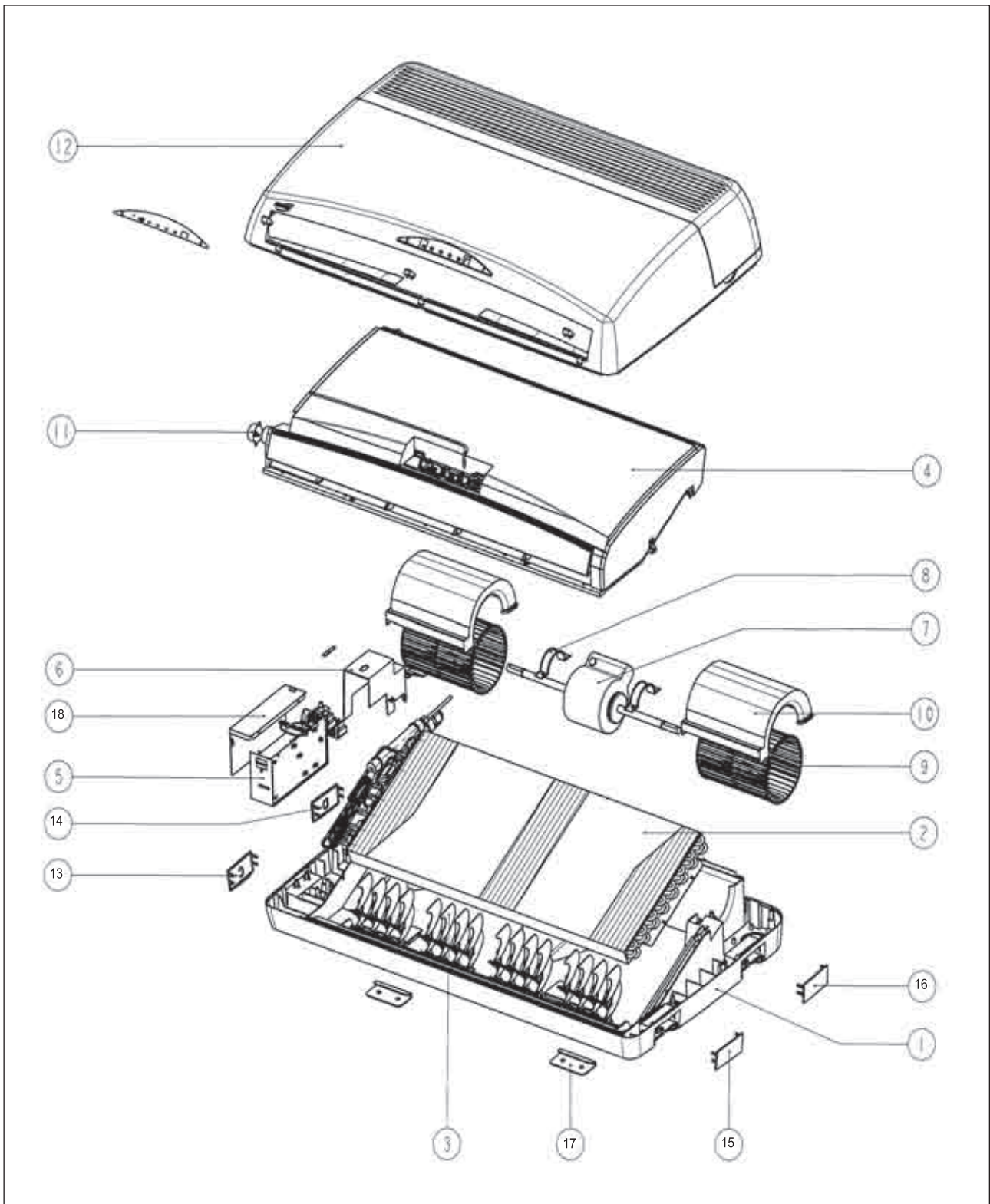

Note: All exploded view and part list are subjected to change by the manufacturer without prior notice

Indoor Unit

Model: M5CMY 15/20/25ER

No	Description
1	Assy. Top Panel
2	Assy. Heat Exchanger
3	Assy. Vane
4	Assy. Drain Pan
5	Assy. Control Box
6	Terminal Box Cover
7	Motor
8	Bracket, Motor
9	Blower
10	Housing, Blower
11	Motor, Louver

No	Description
12	Assy. Panel Bottom
13	Cover, Hanger L1 (C)
14	Cover, Hanger L2 (D)
15	Cover, Hanger R1 (A)
16	Cover, Hanger R2 (B)
17	Bracket, Mounting
18	Control Box Cover
Parts Not in Diagram	
	Handset, Wireless
	Control Module
	Intake Grille

Note: All exploded view and part list are subjected to change by the manufacturer without prior notice

